

Tillage Haulage Landscaping Seeding & Plantation

Crop Protection Harvest Post Harvest

Solutions...



31-08-2019

FIELDKING
USA

Roto Multi Crop Planter



FIELDKING USA, INC.

960 Holmdel Road Suite 2-02, Holmdel, NJ 07733, USA

✉ exports@fieldking.com, www.fieldking.com

➤ [Operator Manual](#) ➤ [Service Manual](#) ➤ [Part Catalogue](#)

CONGRATULATIONS!

You have invested in one of the best implements of its type in the market today.

The care you give your "FIELDKING USA" implement will greatly determine your satisfaction with its performance and its service life. A careful study of this manual will give you a thorough understanding of your new implement before operating.

If your manual is lost or destroyed, "FIELDKING USA" will be glad to provide you a new copy. Visit to nearest dealership & get a copy. Most of our manuals can also be downloaded from our website at www.fieldking.com.

As an authorized "FIELDKING USA" dealer, we stock genuine "FIELDKING USA" parts which are manufactured with the same precision and skill as our original equipment. Our trained service persons are well informed on methods required to service "FIELDKING USA" equipments and are ready to help you.

Should you require additional information or assistance, please contact us.

YOUR AUTHORIZED

FIELDKING USA DEALER

BECAUSE "FIELDKING USA" MAINTAINS AN ONGOING PROGRAMME OF PRODUCT IMPROVEMENT, WE RESERVE THE RIGHT TO MAKE IMPROVEMENTS IN DESIGN OR CHANGE IN SPECIFICATION WITHOUT INCURRING ANY OBLIGATION TO INSTALL THEM ON UNITS PREVIOUSLY SOLD. BECAUSE OF THE POSSIBILITY THAT SOME PHOTOGRAPHS IN THIS MANUAL WERE TAKEN OF PROTOTYPE MODELS, PRODUCTION MODELS MAY VARY IN SOME DETAIL. IN ADDITION, SOME PHOTOGRAPHS MAY SHOW SHIELDS REMOVED FOR THE PURPOSE OF CLARITY. NEVER OPERATE THIS IMPLEMENT WITHOUT ALL SHIELDS IN PLACE.

TO THE PURCHASER

This manual contains valuable information about your new “FIELDKING USA” Roto Multi Crop Planter. It has been carefully prepared to give you helpful suggestions for operating, adjusting, servicing and ordering spare parts.

Keep this manual in a convenient place for quick and easy reference. Study it carefully. You have purchased a dependable and sturdy Roto Multi Crop Planter but only by proper care and operation you can expect to receive the service and long life designed and built into it.

Sometime in the future your Roto Multi Crop Planter may need new parts to replace which are worn out or broken. If so, go to your dealer and provide him equipment's detail like model and part number.

CUSTOMER INFORMATION

Name _____

Purchased From _____

Date of Purchase _____

Model No. _____

Serial No. _____

PURCHASER / OPERATOR'S RESPONSIBILITY

1. Read and understand the information contained in this manual.
2. Operate, lubricate, assemble and maintain the equipment in accordance with all instructions and safety procedures in this manual.
3. Inspect the equipment and replace or repair any parts that are damaged or worn out which under continued operation would cause damage, wear to other parts, or cause a safety hazard.
4. Return the equipment or parts to the authorized “FIELDKING USA” dealer, from where it was purchased, for service or replacement of defective parts that are covered by warranty. (The “FIELDKING USA” Factory may inspect equipment or parts before warranty claims are honored.)
5. All costs incurred by the dealer for traveling to or transporting the equipment for warranty inspection and claims will be borne by the customer.

INDEX

1. TECHNICAL DATA

- 1.1 Introduction
- 1.2 Warning signal
- 1.3 Danger signal
- 1.4 Personal protective equipment
- 1.5 Equipment safety guidelines
- 1.6 Indicator signal
- 1.7 Identification

2. SAFETY AND ACCIDENT PREVENTIONS

3. INSTRUCTIONS FOR OPERATOR

- 3.1 Machines supplied partly broken-down
- 3.2 Before use
- 3.3 Hitching to the tractor
- 3.4 Cardan shaft
- 3.5 Working depth
- 3.6 Chain tensioner
- 3.7 Hoe blades
- 3.8 In working
- 3.9 How it works
- 3.10 Troubleshooting hints for the tractor operator
- 3.11 Parking

4. MAINTENANCE

- 4.1 Every 8 work hours
- 4.2 Every 50 work hours
- 4.3 Every 200 work hours
- 4.4 Storage
- 4.5 Lubrication

5. SERVICING TIPS

6. Seed Box

7. Seed metering mechanism

8. PTO Shaft

9. Drive wheel

10. Seed delivery pipes

11. Hitching of machine

12. Operating the Roto Multi Crop Planter

Parts Catalogue

NOTE:

FIELDKING USA reserves the right to modify machine design and specifications provided herein without any preliminary notice. Information provided herein is of descriptive nature. Performance quality may depend on soil quality.

1. TECHNICAL DATA

1.1 INTRODUCTION

Roto Multi Crop Planter

Being a trusted name of this domain; we are manufacturing, supplying, importing and exporting optimum performing Roto Multi Crop Planter. Offered drills are commonly used for sowing different types of crops such as maize, wheat, pea and mustard among others. Our offered Roto Multi Crop Planter is widely acknowledged among the clients for its remarkable features like low maintenance, simple to handle, easy operation and longer functional life.

Benefits of Roto Multi Crop Planter

- It prepares the field for seeding in first go only.
- Saves more time and Prevents the tractor from wear and tear.
- More fuel efficient and preserves the moisture in the soil.
- Performs well in every type of soils wet or dry
- It is very helpful in Wheat, Grass Seeds & Clover farms.
- Our highly efficient Planter is extensively used for sowing a wide variety of crops like maize, wheat, pea, mustard etc. Roto Multi Crop Planter provided by us is in huge demand in the market for durability, high speed and performance. Our low maintenance Machine is easy to operate and handle. We are counted among the prominent Agriculture Roto Multi Crop Planter Manufacturers based in India.

Special Features:

- Specially designed tampered blades made of high quality steel
- Gear helps it to work smoothly & efficiently
- Frame made of heavy duty pipes
- Export quality heavy duty gear box
- Nuts & bolts made of high tensile steel
- Every part made with computerized CNC machine
- Useful and Idle for removing stubble of sugarcane, cotton, banana, Jowar, maize and roots of various other crops

Compliance with the instructions in this handbook is also important though manufacturer declines all and every responsibility for damage to persons or property caused by negligence and failure to comply with these instructions.

The manufacturer shall, however, remain at the customer's disposal for immediate and thorough assistance together with anything else that may be required in order to ensure the correct operation and maximum efficiency of the implement.



1.2 WARNING SIGNAL

REMEMBER SAFETY FIRST

Operator must read the instruction manual before operating the rotary tiller. Do not allow anyone to operate this equipment who has not fully read and comprehended this manual and who has not been properly trained in the safe operation of the equipment.



1.3 DANGER SIGNAL

1. Sharp objects could be thrown up keep a safe distance from the rotary tiller.



2. Risk of injury to leg



3. Keep away from the moving parts. Never remove guards while working.



4. Your implement is not designed to carry passengers - NO RIDER



5. Never allow anyone to stand between the tractor and implement while an operator is backing up to the implement.



6. Keep away from the cardan shaft. Keep away from the moving parts.



1.4 PERSONAL PROTECTIVE EQUIPMENT



1. Do not wear loose fitting dress, dangling jewellery. Long hair should be tied back to avoid entangling.
2. Wear appropriate footwear. Soft cloth shoes or sandals are not safe around any type of equipment.
3. Wear hearing protection such as earplugs or other devices that will minimize sounds. But will not interfere with your ability to hear traffic or other noises that may alert you to potential hazards.
4. Do not operate any machinery while talking on a cell phone or other portable devices such as MP3 players, as these are considered distractions- operating any farm equipment requires the operator's full attention.

1.5 EQUIPMENT SAFETY GUIDELINES



1. Read safety instructions for both the tractor and this tiller before use.
2. Never exceed the advised limits of the tractor or the tiller.
3. This equipment is dangerous to children and those unfamiliar with its operation. DO NOT ALLOW children to operate or play around equipment.
4. Operator should be an adult who is familiar with operating the tractor and the tiller.

Operator should be physically and mentally fit before operating machinery. Fatigue, stress, alcohol and drugs may impair the ability for safe farm machinery operation.

1.6 INDICATOR SIGNALS

1. Coupling point for lifting (Indicating the maximum capacity)
2. Oil fill plug.
3. Oil drain Plug.
4. Oil Level Plug.
5. Greasing point.
6. Identification Plate.

1.7 IDENTIFICATION

Each individual rotary tiller has an identification plate indicating the following details, which should be copied into the handbook along with the date of purchase:

1. Machine type.
2. Machine model.
3. Serial number.
4. Year of manufacture.

2. SAFETY AND ACCIDENT PREVENTION

Pay great attention to the danger signal indicated in this handbook. There are three types of danger signals:

Danger: This signal warns for serious injuries, death or long-term health risks would be caused by failure to correctly carry out the described operations.

Warning: This signal warns for serious injuries, death or long-term health risks that can be caused by failure to correctly carry out the described operations.

Caution: This signal warns for damage to the machine could be caused by failure to carry out the described operations.

Thoroughly read all the instructions before using the rotary tiller. Contact the technicians of your authorized dealer in case of doubt. The manufacturer declines all and every responsibility for injury/accidents in event of non-compliance of following safety and accident preventing provisions.

- 1) Comply with the instructions given by the danger symbols in this handbook and affixed to the steerage hoe itself.
- 2) Never touch any moving part.
- 3) Minor maintenance and adjustments to the rotary tiller must always be carried out when the engine is off and the tractor braked.
- 4) It is absolutely forbidden to carry passengers or any animals on the rotary tiller.
- 5) It is absolutely forbidden for a person without a driving license, untrained person or those in precarious health conditions to drive the tractor with the rotary tiller mounted.
- 6) Strictly comply with all the recommended accident preventing measures described in this handbook.
- 7) Assembly of a rotary tiller on the tractor will shift the weights on the axles. It is therefore advisable to add weights to the front part of the tractor in order to balance the weights on the axles themselves.
- 8) The coupled implement may only be controlled through the cardan shaft complete with the necessary safety devices for overloads and with the appropriate chains. Keep away from the cardan shaft while it is turning.
- 9) Before starting the tractor and implement, always check that all safety devices guarding transport and use are in perfect conditions.
- 10) The instruction labels affixed to the machine give useful advice on how to prevent accidents.
- 11) Always comply with the Highway Code in force in your country, when travelling on public roads.
- 12) Comply with the maximum permissible weight on the axle of the tractor, the total adjustable weight, transport regulations and the highway code.
- 13) Always be familiar with the controls and their operation before starting to work.
- 14) Avoid sharp turns as this may cause implement to ride up on the tractor's wheels and might result in serious injury and damage to your equipment.
- 15) As indicated, couple the implement to a tractor of adequate power and configuration, using a device (lift) conforming to the precautions.
- 16) Take the utmost care during the implement coupling and release phases.
- 17) Any accessories for transport must be equipped with adequate signals and guards.
- 18) Never leave the driving seat while the tractor is moving.
- 19) It is very important to remember that the road holding, steering and braking capacity may be notably influenced by the presence of towed or mounted implement.
- 20) Always take care of the centrifugal force exercised by the position of the center of gravity, when turning corners with the implement mounted.
- 21) Before engaging the PTO, check that the rpm rate is the same as prescribed. Never exchange the 540-rpm rate for 1000-rpm or vice versa.
- 22) It is absolutely forbidden to stand within the operative range of the machine where there are moving parts.
- 23) Before leaving the tractor, lower the implement coupled to the lift unit, stop the engine, engage the hand brake and remove the ignition key from the control panel.

- 24) It is strictly prohibited to stand between the tractor and the implement when the engine is running and the cardan shaft is engaging without having first engaged the hand brake and placing a block or stone under the wheels to prevent them from moving.
- 25) Always set the lift control lever to the locked position before coupling or releasing the equipment from the three-point coupling.
- 26) The category of the implement coupling pins should correspond to that of lift coupling.
- 27) Take care when working near the lift links. This is a very dangerous zone.
- 28) It is absolutely forbidden to stand between the tractor and the implement when handling the lift control from outside.
- 29) Fix the side lift links with the relative chains and idlers during the transport phase.
- 30) Set the control lever of the hydraulic lift to the locked position during road transport with the implement raised.
- 31) Only use the cardan shaft recommended by the manufacturer.
- 32) Check the cardan shaft guard frequently and periodically. It must always be in a proper condition.
- 33) Take great care of the cardan shaft guard, both in the transport and working positions.
- 34) The cardan shaft must only be installed or dismantled whilst the engine is off.
- 35) Take great care to ensure that the cardan shaft is correctly assembled and safe, and carefully check the P.T.O. of the rotary tiller and of the tractor.
- 36) Lock the rotation of the protection devices and read the respective cardan shaft Instruction manual thoroughly.
- 37) Before engaging the PTO, ensure that there's nobody in the field of action of the machine and that the selected running rate corresponds to the permissible value.
- 38) Never engage the PTO when the engine is on.
- 39) Always disengage the PTO when the cardan shaft is set at an excessively open angle (never beyond 10 degrees) and when it is not in use.
- 40) Only clean and grease the cardan shaft when the PTO is disengaged, the engine is off, the handbrake engaged and the ignition key is removed.
- 41) Rest the cardan shaft on its stand when not in use.
- 42) Refit the protective cap on the PTO shaft after having dismantled the cardan shaft.
- 43) Over use of the machine can overheat the gear box unit and parts of the hydraulic circuit. Never touch these parts immediately after use as they are very hot and can cause burns.
- 44) Never carry out maintenance or cleaning work unless the PTO has been disengaged, the engine switched off, the hand brake engaged and the tractor locked in position by a block or stone under the wheels.
- 45) Periodically check for all nuts and bolts to be fully tightened. Re-tighten them if necessary.
- 46) Always place adequate supports under the implement when servicing the machine or replacing the hoe blades with the implement raised.
- 47) Before working on the rotary tiller rotor, disengage the PTO, switch off the tractor engine, engage the hand brake and check that the blades are still.
- 48) Only use the recommended oils & grease.
- 49) The spare parts must correspond to the requirements established by the manufacturer. Only use genuine spare parts.
- 50) The safety instructions must always be perfectly visible. They must be kept clean and should be replaced if they become illegible. Replacements are available on request from your local dealer.
- 51) The instruction manual must be kept for as long as the machines last.

3. INSTRUCTIONS FOR OPERATOR

MACHINES SUPPLIED PARTLY

3.1 BROKEN-DOWN

When large volumes are involved, machines can be supplied with parts detached or removed (but always in the same packaging units).

Normally the 3-point frame is shipped separate and will later be fixed to the machine at the customer premises. Execute these installation operations with the utmost care.

Refer to the list of parts in the spare parts catalogue. In particular, apply the screw tightening torques as listed in the chart.

3.2 BEFORE USE

Before starting the machine, check that:

1. The machine is perfectly in order that the lubricants are at the correct levels.
2. Check the rotary tiller is correctly fitted & positioned to obtain the right working depth.
3. Check air breather valve is fitted on gear box and side gear cover.

WARNING

None of the following servicing, adjustment and the preparation operations should be carried out unless the PTO is disengaged, the machine is on the ground, the tractor engine is off and the tractor itself is safely parked & braked.

3.3 HITCHING TO THE TRACTOR

The rotary tiller is coupled to the tractor when the tiller is on the ground. The ground area should be flat.

All the rotary tillers can be attached to any tractor with a class 1 or 2 universal 3-point hitch.

Depending on the precise dimensions of these two of hitches, find the best position for the rotary tiller by moving the front plates along the square tube and insert the pin in the holes corresponding to the correct diameter for the tractor's parallel arms.

DANGER

Mounting of any implement to a tractor is a very dangerous operation and must only be carried out with the utmost care in compliance with the instructions.

The correct tractor/steerage hoe position is established by setting the implement at such a distance from the tractor that the universal coupling remains 2"-4" from its maximum closing position. Now proceed in the following way:

1. Near the lift bars, setting them in the most suitable place insert the pin into the relative hole and lock in place with the lynch pins.
2. Lock the lift links using the relative chains and couplings parallel to the tractor.
3. Engage the cardan shaft and check that it is perfectly locked on the PTO. Check that the guard is free to turn and fix it with a relative latch. Remove the cardan shaft support and reposition it by fixing it on the relative hook.
4. Connect the upper third point and correctly regulate by means of the adjuster checking that the upper surface of the steerage hoe is parallel to the ground. This is very important since it achieves parallelism between the axis of the steerage hoe and that of the tractor PTO. When the implement operates in these conditions, there will be less stress on the PTO itself while the cardan shaft and implement will be much less subjected to wear.
5. Besides supporting the leveling plate and acting as shock absorber for it during road transport, the spring ram prevents the steerage hoe from overturning when parking. The effect of the leveling plate on the soil can be increased or decreased depending upon the position, established by the split pin in the various holes in the ram tube.

6. When the machine is operating parking stand should be removed. Parking stand should only be installed when the rotary tiller has been lowered to the ground & the machine is parked.

3.4 CARDAN SHAFT

Cardan Shaft adaptation

The cardan shaft, supplied with the machine, is of standard length. Therefore, it might be required to adapt the cardan shaft. In that case, before taking any step consult the Manufacturer for the eventual adaptation.

CAUTION

When the cardan shaft is fully extended, the two tubes must overlap by at least 4"-6". When fully inserted, the minimum play must be 1.6".

If the implement is used on another tractor, always check that the guards completely cover the rotating parts of the cardan shaft.

CAUTION

1. Never allow the steerage hoe to operate out of the soil. During work, avoid turning corners while the implement is working. Never work in reverse. Always raise the implement in order to reverse or change direction.
2. During transport, or whenever the implement must be raised, it is advisable to adjust the lift unit of the tractor so that the implement itself is not raised more than about 1.3' from the ground.
3. Do not drive on public highways if the machine is dirtied with soil, grass as it hampers the road traffic.
4. Lower the machine slowly to allow the blades to gradually penetrate the soil.
5. Do not allow it to drop violently on to the ground. To do this would strongly stress all the machine components and could damage them.

3.5 WORKING DEPTH

Rotary tiller working depth is regulated on the basis of the position of the following devices:

1. Side skids

Machine with skids: To adjust working depth on this type of machine you must loosen the adjustment pin and raise or lower the skid to the desired extent. Then reposition the pin. Both skids should be subjected to this operation, which will vary according to the type of soil.

3.6 CHAIN TENSIONER

A special mechanical chain tensioner regulates the tension of the drive chain. This device works against coiled spring tensioner.

3.7 HOE BLADES

Check the degree of wear and condition of the hoe blades daily. If the blades accidentally bend (or break) during work, they must be immediately replaced. Remember to mount the new hoe blade in exactly the same position as the old one. If several hoe blades must be replaced, it is advisable to remove and assemble one hoe blade at a time in order to prevent positioning errors.

The steerage hoes are normally equipped with 4 blades per flange. When the soil is dry to clog it is, however, possible to mount 6 hoe blades per flange. The heads of the bolts fixing the hoe blades in place must be on the side of the hoe blades themselves, while the nut with relative washer must be on the flange side. Apply the tightening torques as listed in the chart. If the hoe blades must be changed, remember to set the new blades in the same positions as the dismantled ones.

3.8 IN WORKING

Start working with the PTO at running rate, gradually lowering the steerage hoe into the soil. Never excessively press down on the accelerator pedal when the PTO is engaged. This could be very harmful for both the steerage hoe and the tractor itself. When choosing how much to break up the soil that is to be rotary hoed the following points must be considered:

1. The type of soil (mixed, sandy, clayed etc.)
2. How deep to hoe
3. The forward moving speed of the rotary tiller/tractor.

The soil is best broken up and rotary hoed with a slow forward moving speed of the tractor, with the leveling blade lowered and a blade carrying rotor rotation speed of about 180-210 rpm. The plank helps to produce a well-leveled and smooth surface after hoeing.

If the plank is raised the sods/clog are no longer broken up and there will not be a smooth, level finish.

3.9 HOW IT WORKS

Position the Plank according to how finely broken soil should be. Position the depth of the two skids that are on the sides of the rotary tiller. Start to move the tractor forward gradually lowering the rotary tiller.

After a short distance check whether the soil is being hoed to the depth required, broken up finely enough and levelled enough.

CAUTIONS

In order to prevent breakages or damage, the speed of the tractor must never exceed 2-5 km/hr while the implement is working.

3.10 TROUBLESHOOTING HINTS FOR THE TRACTOR OPERATOR

INSUFFICIENT DEPTH

1. Check the positioning of the two depth skids.
2. Move forward slower as the power of the tractor may be insufficient.
3. If the soil is too hard a second or third hoeing may be required.
4. If the hoe blades are rotating on top of the soil instead of cutting into it proceed more slowly.

THE SOIL IS TOO FINELY BROKEN UP

1. Raise the leveling blade.
2. Increase the forward moving speed of the tractor.

THE SOIL IS NOT BROKEN UP FINELY ENOUGH

1. Lower the leveling blade.
2. Reduce the tractor speed.
3. Don't work soil that is too wet.
4. In the rotary hoes fitted with a leveling bar, raise or lower this so as to keep the sods closer to the hoe blades.

CLOGGING UP THE ROTOR

1. The soil is too wet for hoeing.
2. Raise the leveling blade.
3. Reduce the tractor speed.
4. Reduce the number of the hoe blades per flange from six to four.
5. Avoid hoeing where there is long grass.

THE ROTARY HOE BOUNCES OVER THE SOIL OR VIBRATES

1. There are foreign bodies caught between the hoe blades.
2. The hoe blades have been incorrectly assembled thereby not forming. The helix shape or with the blunt edge placed to cut into the soil first instead of the cutting edge.
3. Worn or broken hoe blades.
4. The rotor is deformed because of blows to the central part caused by foreign bodies present during hoeing.

OTHER PROBLEMS

The rotary hoe does not hoe to the same depth over the whole width. E.g. if it hoes too deeply on the right side shorten the right arm of the lift bars and regulate the position of the right hand skid.

WORKING ON A HILL/SLOPE

Where possible always try to 'work up' the slope. If this is not possible avoid hoeing along the contours of the hill and hoe up and down the slope to avoid a terracing effect.

PRACTICAL NOTES

The hoed soil should be on the right of the driver the best system is to hoe the alternate strips.

3.11 PARKING

WARNING

Comply with the following instruction in order to ensure that the implement remains stable when released from the tractor.

1. Besides supporting the leveling plate and acting as a shock absorber for it during road transport, the spring ram prevents the steerage hoe from over turning when parking.
2. Hold the cardan shaft with a suitable support.

4. MAINTENANCE

The various servicing operation are listed in the following paragraphs.

Lower running costs and longer machine life depend on constant and methodical compliance with these operations.

CAUTION

The given frequencies are indicative and refer to normal conditions of use. They may therefore be subjected to variations in relation to the type of service, in more or less dusty environment, seasonal factors, etc.

In the case of heavy-duty condition, the maintenance operation should obviously be more frequent.

Before injecting grease into the lubricators, the greasing points must be thoroughly cleaned to prevent mud, dust or foreign bodies from mixing with the lubricants, thus reducing or even annulling its lubricating effect.

When topping up or changing the lubricant, always ensure that the oil is of the same type as that used previously.

WARNING

Always keep oil and greases well away from children's reach. Always thoroughly read the warnings and precautions indicated on the containers.

Avoid contact with the skin.

Always thoroughly and fully wash after use. The utilized oils should be treated in compliance with the current anti-pollution laws.

4.1 EVERY 8 WORK HOURS

Grease the cardan shaft cross journals.

Check that the bolts fixing the hoe blades are well tightened.

4.2 EVERY 50 WORK HOURS

Check the level of the oil in the gearbox or in the reduction unit and top up to the level mark on the rod as necessary.

Transmission lateral part chain: check the level of the oil in the side casing of the transmission unit.

Add oil through the fill plug if necessary. It should flow from the level plug.

4.3 EVERY 200 WORK HOURS

Change the oil in the gearbox or in the reduction unit and transmission casing by completely draining of the old oil through the drain plug, under the reduction unit and through the transmission drain plug.

4.4 STORAGE

It is advisable to proceed in the following way at the end of the season or if the machine is to remain inactive for a long period of time:

1. Wash the implement, particularly removing chemical products and then thoroughly dry it.
2. Carefully check for any damaged or worn parts and replace these if necessary.

3. Fully check screws or bolts, particularly those fixing the hoe blades.
4. Thoroughly lubricate the implement and lastly protect it with a plastic sheet. Store it in a dry place.

Careful compliance with these instructions will be all to the advantage of the user who will be sure to use an implement in perfect conditions when work begins again. Remember that the manufacturer is always at your disposal for any assistance or spare parts as may be required.

4.5 LUBRICANTS

It is advisable to use SAE 140 EP Grade OIL or equivalent for the gear box unit and side transmission.

It is advisable to use high quality grease for all greasing points.

5. SERVICING TIPS

1. **Problem**--P.T.O shaft is rotating with constant speed but not the gear box.

Cause of problem -- Safety bolt might be broken

Solution – Replace the safety bolt.

- a) Remove the P.T.O shaft from the R.T side.
- b) Dislodge the safety bolt and replace it.

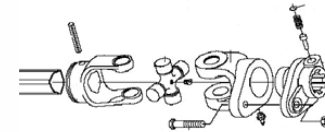

2. **Problem**—P.T.O shaft is making noise/ vibration.

Cause of problem – P.T.O cross is broken.

Solution – Change the P.T.O cross.

- a) Take the P.T.O shaft and check the cross of both side by rotating it.
- b) Remove the lock of the cross which is broken.
- c) Take out the cross by using hammer gently.
- d) Insert the new one properly then lock it.
- e) Rotate the yoke, it should rotate properly.
- f) Make the greasing properly.

3. **Problem**—Yoke is not fitting on the pinion shaft.

Cause of problem – Yoke pin is broken.

Solution – Replace the yoke pin.

- a) Clear the head of the pin push it with with hammer and remove it
- B) Replace it with new one.
- c) Take care of proper cleaning and greasing.

4. **Problem**—Rotary tiller is not taking proper depth.

Cause of problem— Side depth skids need to be adjusted.

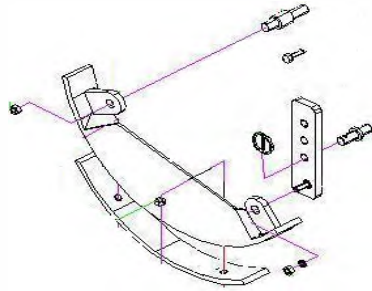

Solution –

- a) Lose the side skid bolt .
- b) Shift the hole to the upper side.

2. **Problem**—R.T. is taking on one side more depth.

Cause of problem –linkage is not proper

Solution –Linkage adjustment should be proper.

- a. Tractor linkage should be tight.
- b. There should not be any play more then 1.5".
- c. At the time of attaching the rotary tiller the R.T should be in proper leveled position.
- d. Both side skids should be in same bolt position.

3. **Problem**—Gear box is noisy.

Cause of problem –Play in bearing or teeth broken.

Solution –Replace the bearing or bevel gear.

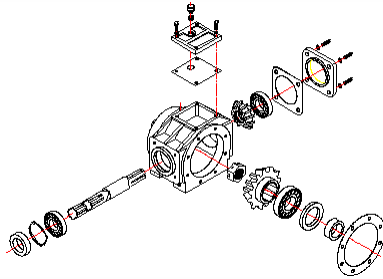

- a) Open the top cover to see the wear of the teeth
- b) If the teeth of the gear is broken the bevel set needs to be replaced.
- c) Pull out the gear box and open the big flange.
- d) Then remove the back plate
- e) Pull out the pinion shaft using hammer or press machine.
- f) Replace the bearing, gear and seals.
- g) Make the fitment in the same way using new gasket.
- h) The gear should rotate freely.
- i) Assemble it back the breather valve should be clean and oiling should be checked.

2. **Problem**—Gear shafts are rotating but not the chain/rotor

Cause of problem –Transmission shaft / chain/ RD shaft is broken

Solution –Open the chain cover and replace the part which is broken.

- a. First remove the lock & loose the check nut.
- b. Pull out the sprocket assembly with chain.
- c. If the transmission shaft is broken, follow the same process as above and replace the shaft then assemble the gear box with rotary tiller.
- d. If chain is broken then replace the chain and assemble the sprockets together with chain & then tighten the check nuts.

For RD shaft the process will be different

- e. First open the flange bolt of the rotor on both side (RD shaft and Dead shaft) and remove the rotor.
- f. Loosen the check nut of RD shaft and hammer it till it gets out from the RD shaft hub & then replace the RD shaft and tight the check nut. Take care of the seal as it should not be harmed with this replacement.

The same process be followed for dead shaft replacement.

3. **Problem**—Oil leakage from the RD shaft hub or dead hub.

Cause of problem –Seal is wearing out needs to be replaced it.

Solution – Open the hub assembly as before

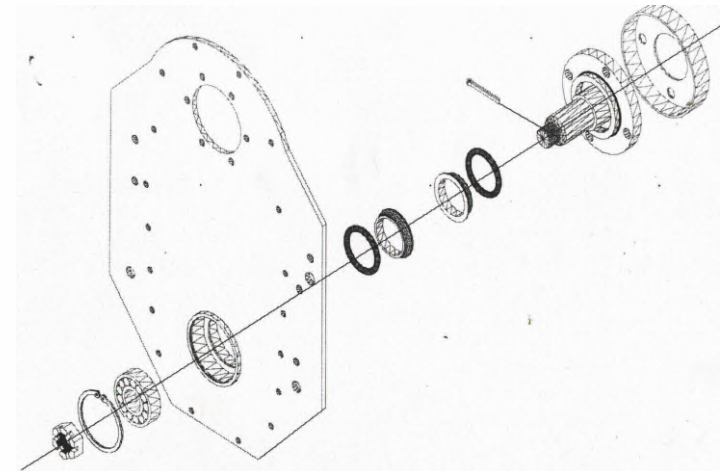

- a. Take out the hub from the plate by loosening the bolts
- b. Remove the lock and pull out the shaft.
- c. Pull out the seal from both shaft and hub then replace it with new one
- d. Inspect the position of bearing and hub if it is ok. Clean it and assemble as before.
- e. Proper greasing is very necessary in assembly processes.

6. Seed Box

The seed box set is depicted in figure 5. Trapezoidal shaped seed boxes are mounted side by side on the frame seed box in the front & rear.



Figure 5
Seed box

7. Seed metering mechanism

The key elements of the seed metering system are depicted in Figure 7, 8 and 9 and described as under

- **Seed box:** It is used to store the seed in the machine
- **Fluted rollers:** Fluted rollers are attached to the shaft. As the shaft rotates, the fluted roller also rotates and seed delivered to the seed delivery pipe through the flow control tongue.
- **Seed rate adjusting lever:** Seed rate adjustment lever is attached to the seed box for increasing or decreasing the rate of seed into the fluted rollers. There is a scale on the adjusting lever which helps us in increasing or decreasing the seed rate.
- **Flow tongue adjustment lever:** There is a flow tongue adjustment lever also. It controls the flow of seed into the seed delivery pipe dropping from fluted roller.

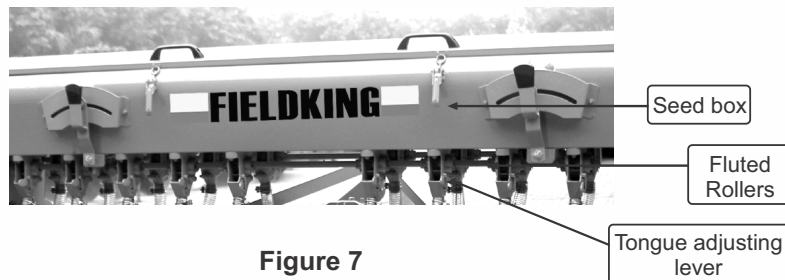

Figure 7
Seed metering mechanism

- **Seed pipe:** It is used to take the seed from flow control tongue to the seed boot
- **Seed boot:** Seed boot finally drops the seed into the slit in the soil opened by the furrow opener.

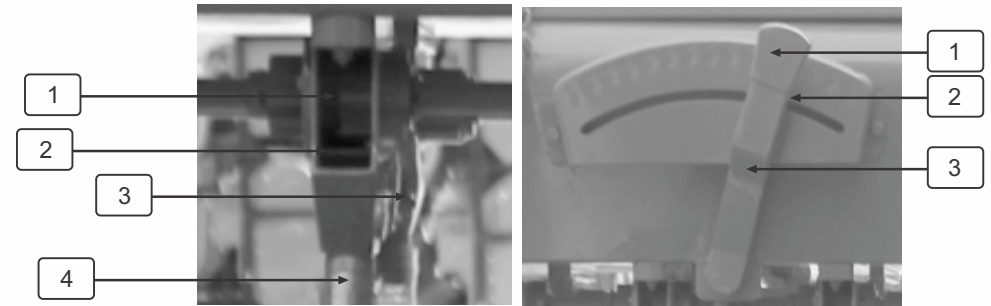

Figure 8

Fluted roller and components
1. Fluted roller 2. Flow tongue
3. Flow tongue adjusting lever
4. Seed pipe

Figure 9

Seed adjustment lever
1. Lever 2. Scale 3. Adjusting nut

2. Seed delivery pipe: It is used to take the seed from cups to the seed boot.
 3. Seed boot: Seed boot finally drops the seed into the slit in the soil opened by the furrow opener.
- ## 8. PTO Shaft
- The power transmission system by the PTO shaft is depicted in Figure 18. PTO shaft provides drive to the flails. The PTO shaft of tractor is first attached to the PTO gear box with the help of PTO attachment shaft. There is a PTO drive shaft in the machine which provides the drive to the PTO drive pulley. A belt joins the PTO drive pulley to the flail drive pulley which rotates the flail shaft and hence, the flails get drive from PTO shaft and start to rotate.
- ## 9. Drive wheel
- Drive wheel provides necessary power to meter the seed delivery from machine to the soil. As the drive wheel rotates, the chain mechanism starts to move through driving and driven shafts as shown in Figure 19 a and 19 b. The chain rolls over the seed sprockets/gear. These sprockets/ gears rotate the seed shafts. As the seed shaft rotates, the fluted rollers (seed metering mechanism) start to work and the seed delivers to the the seed delivery pipes. There is flip gate which can be opened to apply oil/grease to the chain whenever necessary.
- ## 10. Seed delivery pipes
- Seed delivery pipes are attached to the seed box through the seed cups. These pipes carry the seed from the seed metering systems through aluminium flow control tongue/ cups to the seed boot. Tubes should be connected firmly so that these may not come out during field operation. The precautions as outlined below must be taken for fixing/ use of delivery pipes:

- The pipes should be protected from bending and breakage.
- Old/bent pipes should be replaced.
- Excessive bend in the pipes should be avoided otherwise the bend will cause obstruction in free flow of seed and results in non-uniform seed placement and crop establishment.
- The pipes must be inserted about one inch into the seed boot.



Radius of drive Wheel

Take the seed delivery pipes out from the boots and put delivery outlets of the pipes in the polythene bags and tight them using rubber rings. Run the machine and collect the seeds from each delivery pipes after 50 meter run of the machine. The amount of seed collected from each delivery pipes in 50 meter run is then weighed in grams. Then we calculate the seed rate by the given formula

One acre = 43056 sq ft.
 Width of machine = x (ft.)
 Distance = 164 ft.

Weight of seed in pipes = y (Lbs.) Seed rate (Lbs./ acre) =

$$\left(\frac{\text{Weight of seed (Lbs.)} \times \text{Area / acre (1312 sq. ft.)}}{\text{Width of machine (ft.)} \times \text{distance covered (ft.)}} \right)$$

If the seed rates are not as per the desired rates, then re-set the indicators or the inclined plates, gears etc in accordance to the desired rates and repeat the whole process of field calibration as described above.

11. Hitching of machine

The machine has three standard hitch points; two lower and one upper. The machine is attached to tractor through these three hitch points with the help of link pins (Figure 24). The top link hitch point also helps in leveling the machines. The three point hitch adjustments where the machine fixes to the tractor should be adjusted. The machine should be level from side to side and have just enough forward and backward adjustment to enter the soil at the proper angle.

12. Operating the Roto Seed Drill

With the help of three point linkage, the machine is attached to the tractor of optimal capacity (hp) as per the size of machine. After hitching the seed drill, the PTO shaft of tractor is attached to the PTO shaft linkage of machine which gives drive to the flail with the help of belts. The seed drill is to be calibrated and adjusted as per the requirements i.e. seed rate rate, depth of sowing, plant



Hitching of machine through three-point linkage.

to plant spacing as per the crop and field conditions. As the tractor moves, the drive wheel starts to rotate which gives drive to the seed shaft. As the shafts start to move, the seed metering (fluted rollers, inclined plates) also start to move and the seed drops through seed delivery pipes and further to the seed boots. The seed boots are attached to the slits. Now the seed placed into the soil as the furrow openers are penetrating in soil. As the machine gets power from PTO shaft, the flails start rotating and they clean and shift the residue in front of the furrow openers so as the residues doesn't drag and accumulate in seed rows.

12.1 Tips for proper working of the machine

The soil moisture must be optimum for the operation of the machine. For proper operation of Roto Multi Crop Planter, the soil moisture must be slightly lower than the field capacity. The ruts will be formed if the moisture content of the soil is more than optimum which will lead to the uneven placement of the seeds. To obtain the proper efficiency of the machine (uniform and good plant stand) it is advisable to uniformly distribute the crop residue in the field before operating Roto Multi Crop Planter either by straw spreader or manually. There are chances of the more moisture content in the residue in the morning time due to dew which may cause wrapping of the loose straw on the flails which hinders the rotary movement of the flails. Therefore, it is advised to operate the Roto Multi Crop Planter after the dew dries. Adjust the depth of sowing through depth control wheels instead of using the hydraulic lift. Using the hydraulic lift to control the sowing depth may cause the touching of flails to the ground which may damage flails and also cause uprooting of the anchored residue. The ground clearance of the flails must be about 1" to 1.2". The broken flail must be replaced before the further operation of the machine. Otherwise the excessive vibrations in the machine will lead to further breakage of other parts of the machine.

12.2 Maintenance

The machine should be properly serviced and maintained. It should be checked before use to ensure that all the nuts and bolts are tightened and that all the parts are in good condition. The seed boxes should also be in good condition to allow free flow of seed. Chains should be adjusted and oiled. The tension of the belt should be proper. After use at the end of each day, the machine should be checked, the seed boxes cleaned, and the moving parts oiled.

12.3 Operating notes for the machine

12.3.1 Before operation

1. Before operating the Roto Multi Crop Planter for the first time, carefully read this manual and understand all the steps. Become familiar with the mechanism, adjustments and operating methods. Before each use in the field, review this list to make sure all necessary items are checked and adjusted.
2. Preferably the fields should be laser leveled for direct drilling of crops so as to ensure uniformity in soil moisture across the field. Laser land leveling helps in achieving uniform depth of seeding and thus helps to achieve good crop establishment in residue conditions.
3. Ensure that the soil moisture content at the time of planting is optimal and uniform so as to have uniform crop establishment.
4. Soil moisture content is critical for machine operation as excess soil moisture can cause uprooting of anchored residues, followed by machine choking and on the other side low soil moisture affects the wheat germination.
5. Check the condition of the seeder and make any adjustments or repairs necessary. In particular, the fasteners, blade bolts and welds before operating. Replace any broken or worn out parts.
6. Make sure that the seeds to be planted are clean, and free of soil and pebbles.
7. Add the seed to the seed box. Do not fill the seed box more than three quarters full, in order to prevent the buckling of the seed box.

Other Information About Seed Gun Setting

Seed Gun Settings

Each seed gun is equipped with a four-position gate. The highest handle position shown is for small seeds, the second and third positions are for larger seeds. The fourth position (Handle rotated fully down below the bottom tab) sets the wide open to allow complete clean-out of seed gun. Seed quantity is based on the handle being set in the highest position. Typically, most seeds will use the highest handle position. If using larger seed and it is not discharging properly, you can try using the other two handle positions.

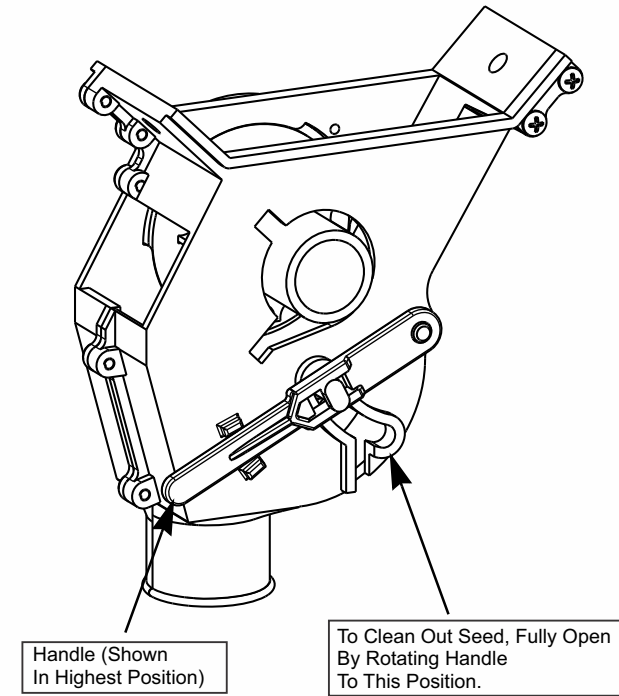

Fig-20

IMPORTANT: Most applications for this seeder require the handle be placed in the highest position.

MAKE SURE all handles are in the same position before seeding. Do Not set handles in the fourth position and seed quantity adjustment lever to the widest open position with seed in the box unless complete clean out is desired.

CALIBRATION CHART

SPREADING CHART FOR WHEAT'S SEED CALIBRATION (LBS. / ACRE, LBS. / HECTARE)												
SEEDS RATE	1	2	3	4	5	6	7	8	9	10	11	12
SEEDS QTY. Lbs. / Acre	17	33	59	75	90	105	123	139	154	169	185	202
SEEDS QTY. Lbs. / Hectare	42	81	146	185	222	260	304	343	380	417	457	497
QTY. KG/ACRE (WHEEL)												
ACRE SIZE= 220 (L) X 198 (W) FEET												
MACHINE SPREADING WIDTH / 6 FEET												
WHEEL SIZE 27"=1 ROUND 8 FEET AREA COVER												
NOTE-TRACTOR SPEED KM/H N/A												

SIDE PLATE AND ROTOR ASSEMBLY			
SR. NO	DESCRIPTION	ITEM CODE	QTY.
1	HEX HEAD BOLT 6X16X1MM (P)	10260359	6
2	DEAD HUB CAP ROUND	10180001	1
3	GASKET DEAD HUB CAP	10040026	1
4	HEX. HEAD BOLT M10X35X1.5	10260353	12
5	SIDE PLATE LHS (18X33X28)	73540004	1
	SIDE PLATE LHS (19X33X25)	70050001	
	SIDE PLATE BIG LHS (18X33X28)	78910002	
	SIDE PLATE BIG LHS (19X33X25)	78910003	
	BERONI RT SIDE PLATE BIG LHS	70040009	
6	SPLIT PIN 1/8X2.5 INCH	10020097	1
7	CASTLE NUT M30X1.5	10280093	1
8	CIRCLIP 95MM	10390014	1
9	BEARING 6308	10050051	1
10	DEAD HUB (OIL SEAL TYPE) (ROUND) NEW	10090021	1
11	PLAIN NUT 10X1.5MM	10280036	12
12	OIL SEAL 55X75X15	10010023	1
13	DEAD SHAFT BUSH	10070042	1
14	DEAD AXLE SHAFT NEW ROUND (OIL SEAL TYPE)	10110002	1
15	ROTOR COVER	10150003	2
16	SPRING WASHER 16MM	10270005	8
17	HEX HEAD BOLT M16X35X1.5MM	10260369	8
ROTOR ASSEMBLY (REGULAR L & C TYPE BLADE)			
18	ROTOR ASSEMBLY (1.00 MTS.)	70030012	1
	ROTOR ASSEMBLY (1.25 MTS.)	73190001	
	ROTOR ASSEMBLY (1.50 MTS.)	73200001	
	ROTOR ASSEMBLY (1.75 MTS.)	73210001	
	ROTOR ASSEMBLY (2.00 MTS.)	73220001	
	ROTOR ASSEMBLY (2.25 MTS.)	73230001	
	ROTOR ASSEMBLY (2.50 MTS.)	73240001	
19	HOE LHS (L TYPE)	10060016	3 PER FLANGE
	HOE LHS (C TYPE)	10060035	
20	HOE RHS (L TYPE)	10060017	3 PER FLANGE
	HOE RHS (C TYPE)	10060034	
21	HEX HEAD BOLT M14X40X1.5MM	10260357	12 PER FLANGE
22	SPRING WASHER 14MM	10270004	12 PER FLANGE
23	NYLOCK NUT M14X2	10280090	12 PER FLANGE
24	RD SHAFT BUSH	10070002	1
25	RD SHAFT (OIL SEAL TYPE) 10 SPLINES	10290017	1
26	OIL SEAL 65X85X16(DOUBLE SPRING TYPE)	10010136	1
27	RD HUB (OIL SEAL TYPE) (ROUND)	10090010	1
28	BEARING 6310	10050053	1
29	CIRCLIP 118MM	10390013	1
30	GASKET RD HUB	10040025	1
31	SIDE PLATE RHS (GEAR TYPE) (18X33X28)	73590002	1
	SIDE PLATE RHS (GEAR TYPE) (19X33X25)	70040004	
ROTOR ASSEMBLY (TERMIVATOR L & C TYPE BLADE)			
32	ROTOR ASSEMBLY (1.45 MTS.)	73340001	1
	ROTOR ASSEMBLY (1.65 MTS.)	73350001	
	ROTOR ASSEMBLY (1.85 MTS.)	73360001	
	ROTOR ASSEMBLY (2.05 MTS.)	73370001	
33	HOE LHS (L TYPE)	10060014	3 PER FLANGE
	HOE LHS (C TYPE)	10060038	
34	HOE RHS (L TYPE)	10060015	3 PER FLANGE
	HOE RHS (C TYPE)	10060039	
ROTOR ASSEMBLY (J- TYPE BLADE)			
35	ROTOR ASSEMBLY (1.00 MTS.)	73200006	1
	ROTOR ASSEMBLY (1.25 MTS.)	73200007	
	ROTOR ASSEMBLY (1.50 MTS.)	73200003	
	ROTOR ASSEMBLY (1.75 MTS.)	73200004	
	ROTOR ASSEMBLY (2.00 MTS.)	73200005	
	ROTOR ASSEMBLY (2.25 MTS.)	73230004	
36	J-TYPE HOE LHS	10060023	3 PER FLANGE
37	J-TYPE HOE RHS	10060022	3 PER FLANGE
38	HEX HEAD BOLT M12X40X1.75MM	10260355	12 PER FLANGE
39	SPRING WASHER 12MM	10270003	12 PER FLANGE
40	NYLOCK NUT M12X1.75	10280025	12 PER FLANGE

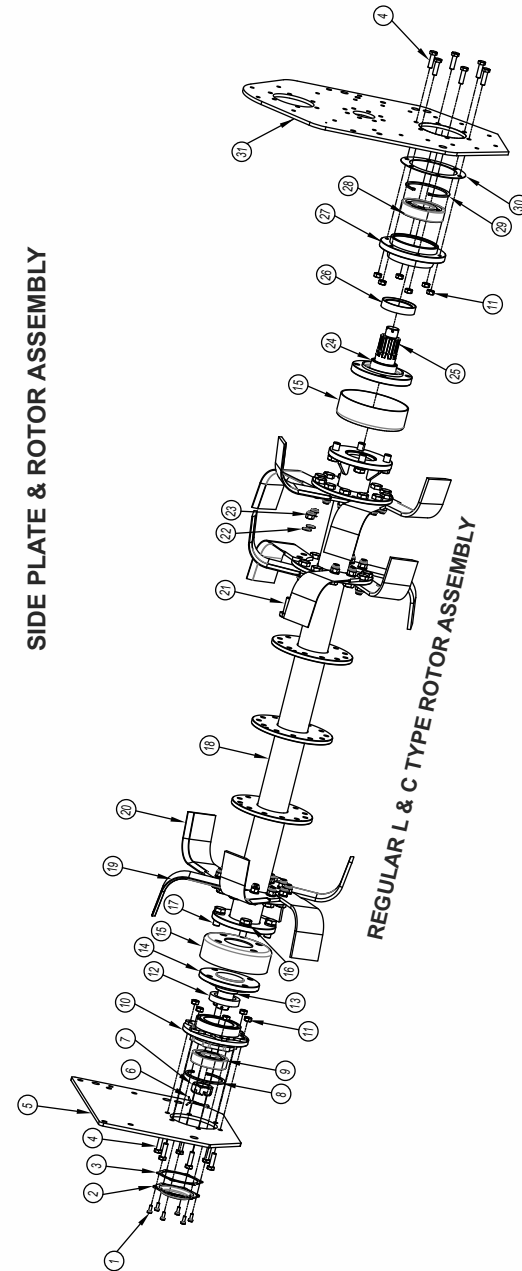

ROTARY TILLER COMPLETE ASSEMBLY			
SR. NO	ITEM CODE	DESCRIPTION	QTY.
1	10260373	HEX HEAD BOLT M8X40	2
2	10260360	HEX HEAD BOLT M8X25	16
3	10150006	GEAR COVER	1
4	10280010	BREATHER NUT 22X1.5	2
5	10190001	BREATHER VALVE	2
6	10040016	GASKET CHAIN/ GEAR COVER	1
7	10020097	SPLIT PIN 1/8 2.5"	1
8	10280093	CASTLE NUT 30X1.5	3
9	10280071	CASTLE NUT 36X2	1
10	10020097	SPLIT PIN 1/8 2.5 INCH	4
11	10050013	BEARING 32209	1
12	10300096	SPACER 45X4	1
13	10250001	SPUR GEAR 18-14S	1
	10250023	SPUR GEAR 18- 8S	1
	10250004	SPUR GEAR 19-14S	1
	10250029	SPUR GEAR 19-8S	1
14	10250015	SPUR GEAR Z33	1
15	10250019	SPUR GEAR 28-10S	1
	10250030	SPUR GEAR 25-10S	1
16	10390032	CIRCLIP B85	1
17	10020004	IDLER PIN	1
18	10290017	RD SHAFT NEW	1
19	10260362	HEX HEAD BOLT M12X1.75X35	6
20	10270003	SPRING WASHER M12	6
21	10280025	NYLOCK NUT M12X1.75	6
22	10260353	HEX HEAD BOLT M10X1.5X35	20
23	10270002	SPRING WASHER M10	6
24	10280036	PLAN NUT M10	12
25	10260399	HEX HEAD BOLT M14 X60 X 2	4
26	10270010	PLAN WASHER M12	4
27	10220022	TRANSMISSION PIPE CLAMP LOWER	2
28	10220021	TRANSMISSION PIPE CLAMP UPPER	2
29	73570003	REAR LEVER	2
30	73570002	FRONT LEVER	2
31	10260367	HEX HEAD BOLT M16X2X125	1
32	10070004	BUSH	1
33	10270005	SPRING WASHER M16	1
34	10280005	NYLOCK NUT M16X2	1
35	10280006	NYLOCK NUT M18X1.5P	6
36	10020001	DEPTH SKID PIN-1	1
37	10270006	SPRING WASHER M18	4
38	71570007	DEPTH SKID SUPPORT BEND STRIP LOWER	1
39	71570008	DEPTH SKID ADJUSTER	1
40	73420001	DEPTH SKID ASSEMBLY LHS	1
41	71570001	DEPTH SKID ASSEMBLY RHS	1
42	10260067	HEX HEAD BOLT M14X1.5X35	4
43	10270004	SPRING WASHER M14	4
44	71570011	DEPTH SKID UPPER STRIP ASSEMBLY RHS	1
45	10260049	CSK BOLT M12X1.75X35	2

ROTARY TILLER ASSEMBLY

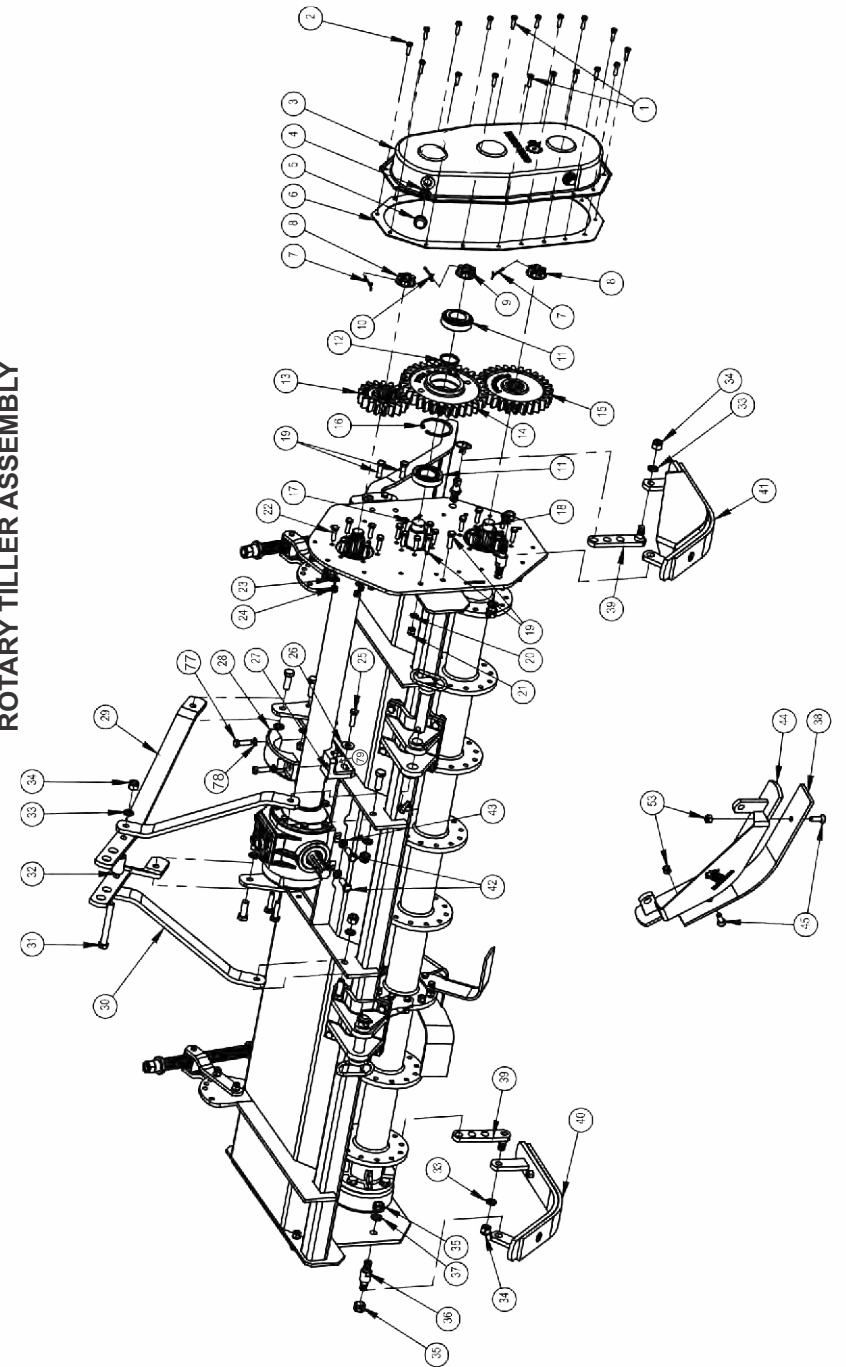

ROTARY TILLER COMPLETE ASSEMBLY			
SR. NO	ITEM CODE	DESCRIPTION	QTY.
46	10160006	SHOCKER ROD	2
47	20050422	RIMIT 5X35	2
48	10180018	SHOCKER SPRING CUP LOWER	2
49	10210002	SHOCKER SPRING BIG	2
50	10070003	SQUARE BUSH	2
51	10210003	SHOCKER SRING SMALL	2
52	10180002	SHOCKER SPRING CUP UPPER	2
53	10280028	PLAIN NUT M12X1.75	2
54	70020040	PLANK ROD NEW 2.75 MTR	
	70020039	PLANK ROD NEW 2.50 MTR	
	70020028	PLANK ROD NEW 2.25 MTR	
	70020029	PLANK ROD NEW 2 MTR	
	70020030	PLANK ROD NEW 1.75 MTR	
	70020031	PLANK ROD NEW 1.5 MTR	
	70020032	PLANK ROD NEW 1.25 MTR	
	70020033	PLANK ROD NEW 1 MTR	
	70020037	PLANK ROD NEW 2.05MTR	
	70020036	PLANK ROD NEW 1.85 MTR	
70020035	PLANK ROD NEW 1.65 MTR		
70020034	PLANK ROD NEW 1.45 MTR		
55	10040005	GASKET SMALL FLAGE 6 HOLE	1
56	10260364	HEX HEAD BOLT 12X1.75X90	2
57	73180001	SHOCKER ASSEMBLY	2
58	70020011	PLANK SIDE SUPPORT RHS	1
59	70020027	PLANK SIDE SUPPORT LHS	1
60	10220003	SHOCKER -PLANK ATTACHMENT U CLAMP	2
61	73130001	PLANK ASSEMBLY 2.75MTR	1
	73120001	PLANK ASSEMBLY 2.50MTR	1
	73110001	PLANK ASSEMBLY 2.25MTR	1
	73100001	PLANK ASSEMBLY 2MTR	1
	73090001	PLANK ASSEMBLY 1.75MTR	1
	73080001	PLANK ASSEMBLY 1.5MTR	1
	70020013	PLANK ASSEMBLY 1.25MTR	1
	70020024	PLANK ASSEMBLY 1MTR	1
	73170001	PLANK ASSEMBLY 2.05MTR	1
	73160001	PLANK ASSEMBLY 1.85MTR	1
73150001	PLANK ASSEMBLY 1.65MTR	1	
73140001	PLANK ASSEMBLY 1.45MTR	1	
62	10260113	CSK BOLT M10X1.5X35	2
63	70020026	SHOCKER PLANK ATTACHMENT INNER SUPPORT PLATE	2
64	10280002	NYLOCK NUT M10X1.5	4
65	10020002	DEPTH SKID PIN-2	1
66	10020045	LINCH PIN 8MM	1
67	70020012	FRAM SHOCKER HOLDING CLAMP	4
68	10120005	FRONT LINK BRACKET LOWER	2
69	10120006	FRONT LINK BRACKET UPPER	4
70	10260356	HEX HEAD BOLT 12X1.75X60	8
71	10020022	LINCH PIN 10MM	3
72	10020047	TILLER PIN WITH HANDLE 28X145	2
73	10260358	HEX HEAD BOLT M16X2X50	2
74	10300312	GREASE NIPPLE M6X1P	1
75	70110004	REAR LEVER EXTENSION PLATE	2
76	73420002	DEPTH UPPER STRIP ASSEMBLY LHS	1
77	10260378	HEX HEAD BOLT M16X65X2	4
78	10270005	SPRING WASHER 16MM	4
79	10280005	NYLOCK NUT M16X2	4

ROTARY TILLER ASSEMBLY

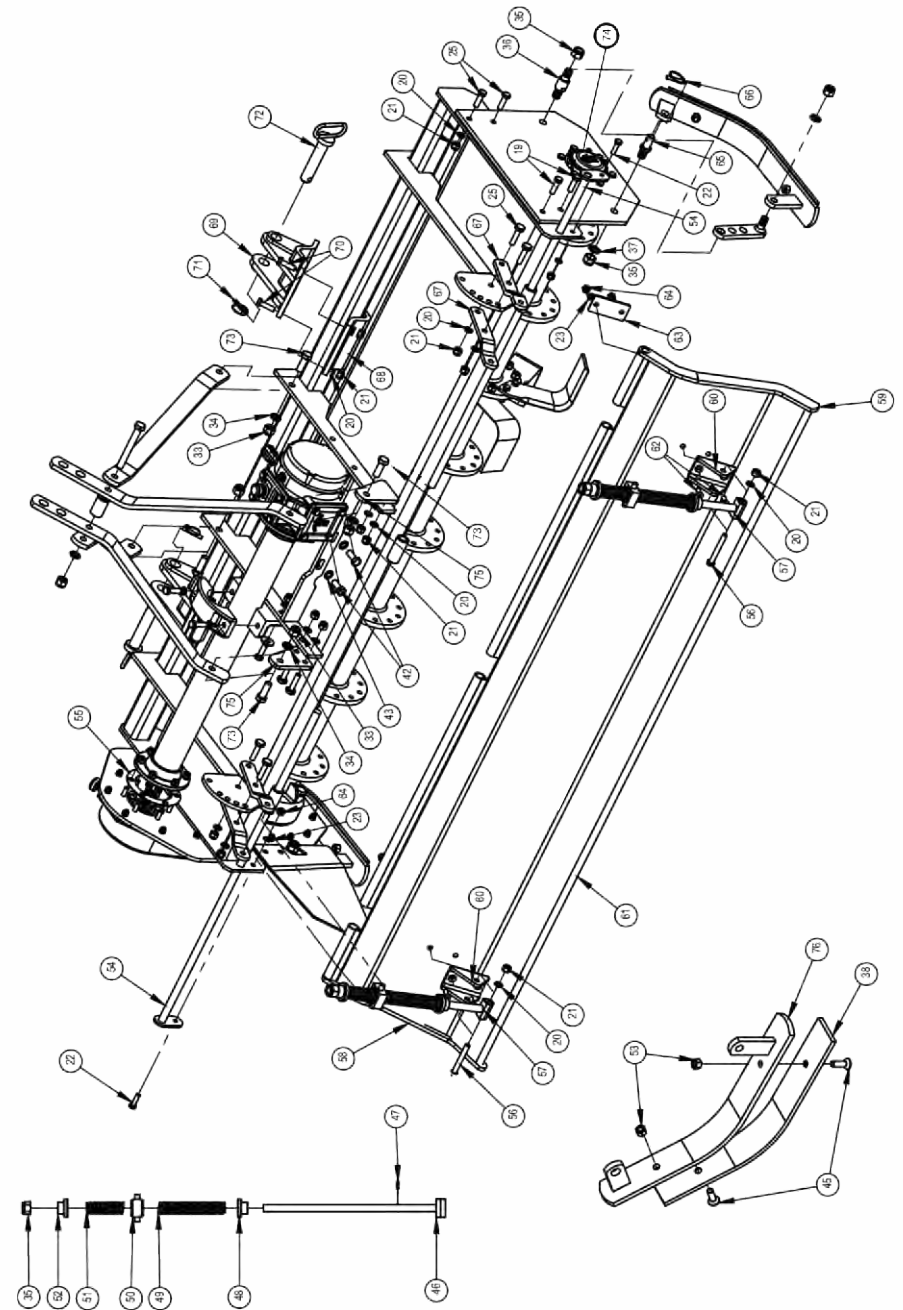

ROTARY TILLER 3-POINT LINKAGE

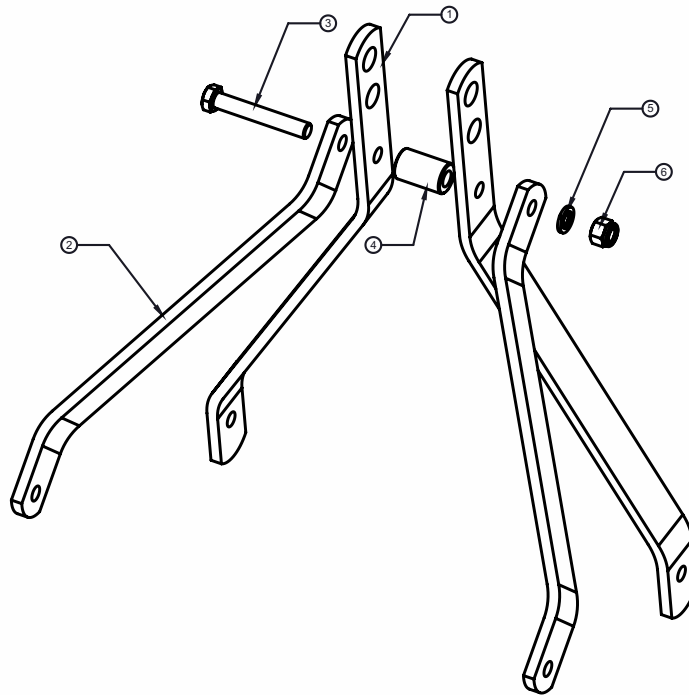

ROTARY TILLER 3-POINT LINKAGE			
SR NO.	DESCRIPTION	ITEM CODE	QTY.
1	Rear Lever	73570003	2
2	Front Lever	73570002	2
3	Hex. Head Bolt M16x2x125	10260367	1
4	Lever Bush	10070004	1
5	Spring Washer 16mm	10270005	1
6	Nylock Nut M16x2	10280005	1

ROTARY TILLER 3-POINT LINKAGE

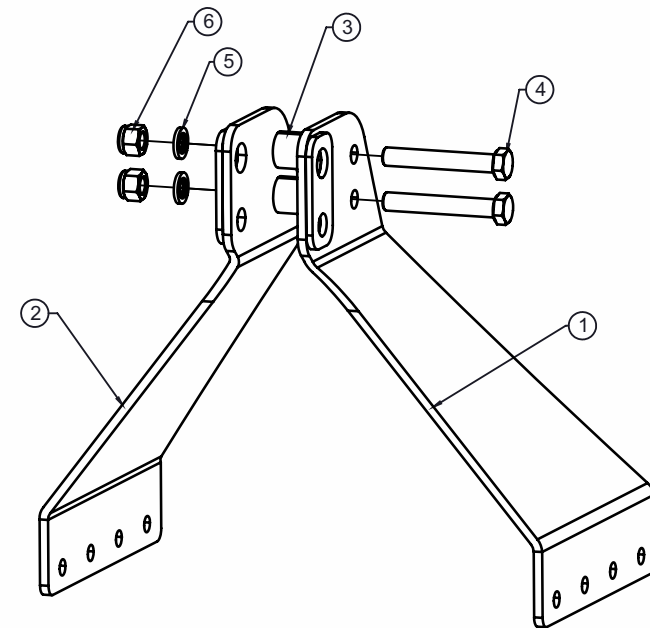

ROTARY TILLER 3-POINT LINKAGE			
SR NO.	DESCRIPTION	ITEM CODE	QTY.
1	REGULAR ROTARY TILLER TPL PLATE - RHS (QUICK HITCH TYPE)	73570054	1
2	REGULAR ROTARY TILLER TPL PLATE - LHS (QUICK HITCH TYPE)	73570053	1
3	BUSH 17X32X64MM (L)	10070173	2
4	HEX HEAD BOLT 16X105X2MM	10260134	2
5	SPRING WASHER 16MM	10270005	2
6	NYLOCK NUT M16X2MM	10280005	2

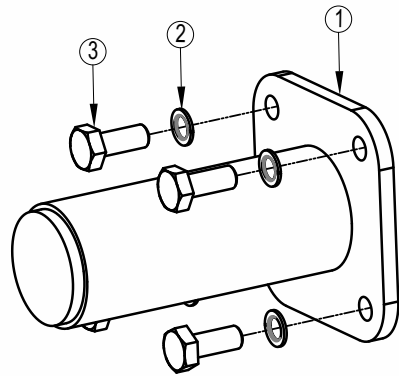

SIDE MOUNTING ASSEMBLY WITH SINGLE-SPEED GEARBOX (11X20)			
SR. NO.	DESCRIPTION	ITEM CODE	QTY.
1	RT GEAR BOX SIDE MOUNTING ASSEMBLY (SINGLE SPEED) (11X20)	74790007	1
2	SPRING WASHER 14MM	10270004	4
3	HEX HEAD BOLT M14X2X35	10260372	4

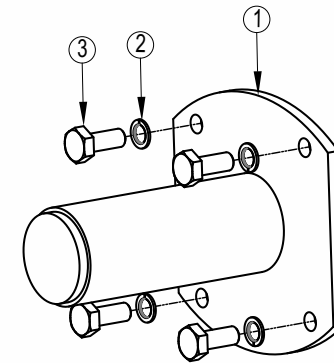

SIDE MOUNTING ASSEMBLY SINGLE-SPEED GEAR BOX (14X25)			
SR NO.	DESCRIPTION	ITEM CODE	QTY.
1	RT GEAR BOX SIDE MOUNTING ASSEMBLY (ROBUST) (14X25)	74790001	1
2	SPRING WASHER 14MM	10270004	4
3	HEX HEAD BOLT M14X2X35	10260372	4

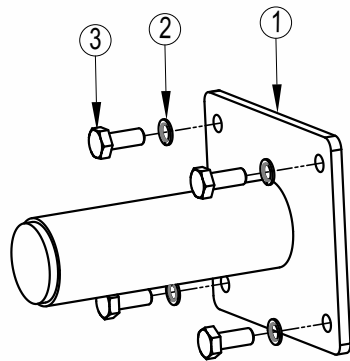

SIDE MOUNTING ASSEMBLY MULTI-SPEED GEARBOX (13X25)			
SR NO.	DESCRIPTION	ITEM CODE	QTY.
1	RT GEAR BOX SIDE MOUNTING ASSEMBLY (MULTISPEED) (13X25)	74790002	1
2	SPRING WASHER 14MM	10270004	4
3	HEX HEAD BOLT M14X2X35	10260372	4

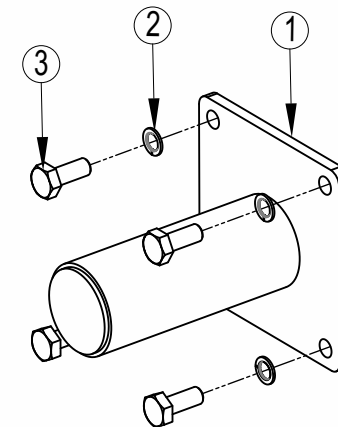

SIDE MOUNTING ASSEMBLY MULTISPEED GEAR BOX (14X25)			
SR NO.	DESCRIPTION	ITEM CODE	QTY.
1	RT GEAR BOX SIDE MOUNTING ASSEMBLY (ROBUST MULTISPEED) (14X25)	74790010	1
2	SPRING WASHER 14MM	10270004	4
3	HEX HEAD BOLT M14X2X35	10260372	4

BOTH SIDE PIPE			
SR.NO.	ERP CODE	ITEM_NAME	QTY
1		GEAR BOX SIDE MOUNTING ASSEMBLY	
	78750039	RT GEAR BIG SIDE MOUNTING ASSEMBLY 1.25 MTR (MULTISPEED)	1
	78750010	RT GEAR BIG SIDE MOUNTING ASSEMBLY 1.25 MTR (SINGLE SPEED)	1
	78750019	RT GEAR BIG SIDE MOUNTING ASSEMBLY 1.50 MTR (MULTISPEED)	1
	78750031	RT GEAR BIG SIDE MOUNTING ASSEMBLY 1.50 MTR (MULTISPEED) C TYPE	1
	78750016	RT GEAR BIG SIDE MOUNTING ASSEMBLY 1.50 MTR (SINGLE SPEED)	1
	78750020	RT GEAR BIG SIDE MOUNTING ASSEMBLY 1.75 MTR (MULTISPEED)	1
	78750033	RT GEAR BIG SIDE MOUNTING ASSEMBLY 1.75 MTR (MULTISPEED) C TYPE	1
	78750023	RT GEAR BIG SIDE MOUNTING ASSEMBLY 1.75 MTR (ROBUST MULTISPEED)	1
	78750036	RT GEAR BIG SIDE MOUNTING ASSEMBLY 1.75 MTR (ROBUST SINGLE SPEED)	1
	78750017	RT GEAR BIG SIDE MOUNTING ASSEMBLY 1.75 MTR (SINGLE SPEED)	1
	78750009	RT GEAR BIG SIDE MOUNTING ASSEMBLY 1.00 MTR (SINGLE SPEED)	1
	78750040	RT GEAR BIG SIDE MOUNTING ASSEMBLY 2.00 MTR (ROBUST SINGLE SPEED)	1
	78750021	RT GEAR BIG SIDE MOUNTING ASSEMBLY 2.00 MTR (MULTISPEED)	1
	78750034	RT GEAR BIG SIDE MOUNTING ASSEMBLY 2.00 MTR (MULTISPEED) C TYPE	1
	78750018	RT GEAR BIG SIDE MOUNTING ASSEMBLY 2.00 MTR (SINGLE SPEED)	1
	78750024	RT GEAR BIG SIDE MOUNTING ASSEMBLY 2.00 MTR(ROBUST MULTISPEED)	1
	78750025	RT GEAR BIG SIDE MOUNTING ASSEMBLY 2.25 MTR (ROBUST MULTISPEED)	1
	78750041	RT GEAR BIG SIDE MOUNTING ASSEMBLY 2.25 MTR (ROBUST SINGLE SPEED)	1
	78750026	RT GEAR BIG SIDE MOUNTING ASSEMBLY 2.50 MTR (ROBUST MULTISPEED)	1
	78750027	RT GEAR BIG SIDE MOUNTING ASSEMBLY 2.75 MTR (ROBUST MULTISPEED)	1
2	78910002	DEAD HUB SIDE PLATE BIG - 18x33x28	1
	78910003	DEAD HUB SIDE PLATE BIG - 19x33x25	
3	10260353	HEX HEAD BOLT M10x1.5x35	6
4	10270002	SPRING WASHER 10MM	6
5	10280002	NYLOCK NUT M10X1.5MM	6

SR.NO.	ERP CODE	PLANK GUARD	QTY
1	10150029	PLANK GUARD LHS	1
2	10150031	PLANK GUARD RHS	1
1	10150025	PTO SAFETY COVER	1

BOTH SIDE PIPE

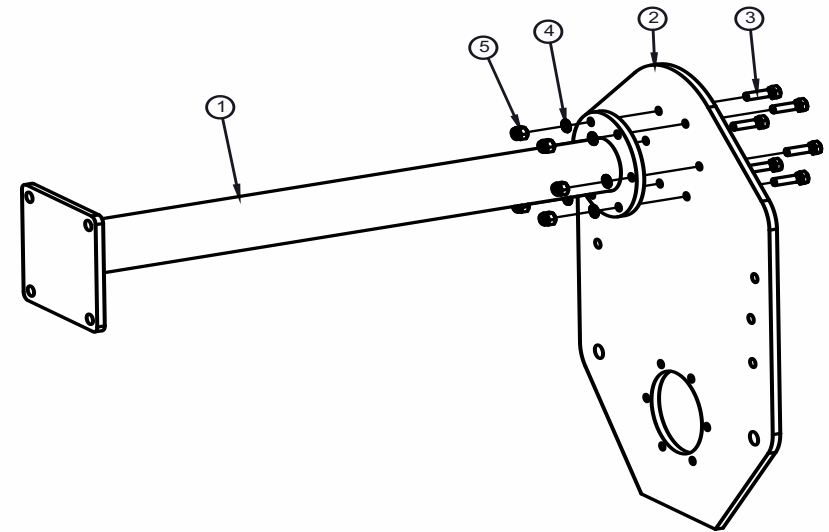

PTO SAFETY COVER

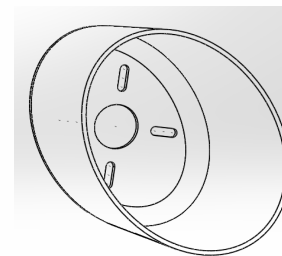

PLANK GAURD

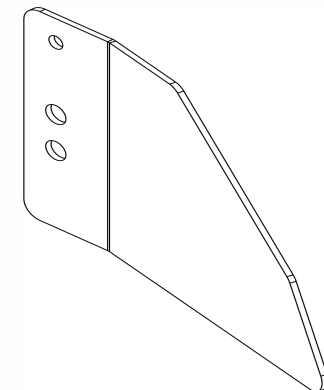

SINGLESPEED(11X20) GEARBOX ASSEMBLY			
SR. NO	DESCRIPTION	ITEM CODE	QTY
1	GEAR BOX HOUSING (SINGLE SPEED)11X20	10080001	1
2	PINION SHAFT (SINGLE SPEED)	10290010	1
3	BEARING 30207	10050100	1
4	CIRCLIP 72MM (INTERNAL)	10390022	1
5	OIL SEAL 35X72X10	10010001	1
6	PINION GEAR 11TX6 SPLINES	10250018	1
7	BEARING 30210	10050097	1
8	CIRCLIP 95MM	10390014	1
9	GEAR BOX REAR BEARING PLATE (SINGLE SPEED)	73620002	1
10	SPRING WASHER 10MM	10270002	14
11	HEX HEAD BOLT M10X30X1.5MM	10260396	12
12	GASKET TOP PLATE GEAR BOX 109X109X1.5MM (11X20)	10040033	1
13	GEAR BOX TOP PLATE	73620003	1
14	DIP STICK	10300001	1
15	BREATHER NUT 22X1.5MM	10280010	1
16	BREATHER VALVE	10190001	1
17	HEX HEAD BOLT M10X25X1.5MM	10260361	2
18	BEARING 32209	10050013	1
19	TRANSMISSION PIPE ASSEMBLY (1.25 MTS.)	71590004	1
	TRANSMISSION PIPE ASSEMBLY-1.45 MTR	73830001	
	TRANSMISSION PIPE ASSEMBLY-1.65 MTR		
	TRANSMISSION PIPE ASSEMBLY-1.85 MTR	73840001	
	TRANSMISSION PIPE ASSEMBLY-2.05 MTR	73850001	
20	GASKET BIG FLANGE (8 HOLE) SS	10040009	1
21	TRANSMISSION SHAFT-1408S-S125	10290006	1
	TRANSMISSION SHAFT 1408S-S145	10290112	
	TRANSMISSION SHAFT 1408S-S165		
	TRANSMISSION SHAFT 1408S-S185	10290113	
	TRANSMISSION SHAFT 1408S-S205	10290114	
22	TRANSMISSION SHAFT BUSH	10070038	1
23	OIL SEAL 55X80X10	10010002	1
24	BEARING 32211	10050009	1
25	BEVEL GEAR 20TX14 SPLINES	10250007	1
26	CASTLE NUT M30X1.5M	10280093	1
27	SPLIT PIN 1/8X2.5 INCH	10020097	1

REGULAR SINGLE SPEED GEAR BOX ASSEMBLY

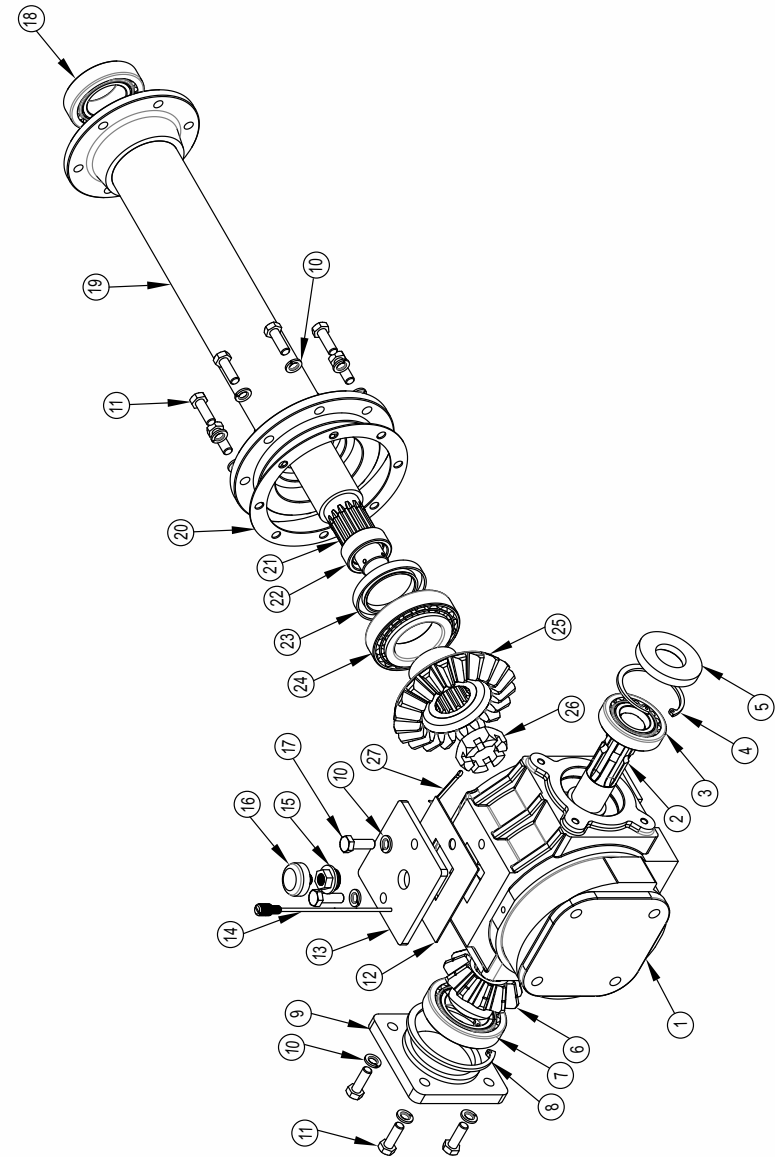

REGULAR MULTI SPEED GEAR BOX ASSEMBLY (13X25)			
SR. NO.	ITEM CODE	DESCRIPTION	QTY.
1	10080002	GEAR BOX HOUSING (13X25 MULTISPEED)	1
2	10050100	BEARING 30207	2
3	10290001	DRIVE SHAFT	1
4	10010006	OIL SEAL 35X62X10	1
5	71940007	MULTI SPEED GEAR BOX FRONT BEARING PLATE ROUND	1
6	71940008	MULTI SPEED GEAR BOX FRONT BEARING PLATE SQUARE	1
7	10040074	GASKET FRONT BEARING PLATE	1
8	10050097	BEARING 30210	2
9	10250016	PINION GEAR 13T-6S	1
10	10290025	PINION SHAFT	1
11	10040042	GASKET GEAR BOX TOP PLATE	1
12	71940009	GEAR BOX TOP PLATE	1
13	10270002	SPRING WASHER 10MM	20
14	10260361	HEX HEAD BOLT M10X1.5X25	4
15	10390029	EXTERNAL CIRCLIP 35 MM	2
16	10250013	SPUR GEAR 20T -6S	1
17	10250033	SPUR GEAR 19T -6S	1
18	10040075	GASKET MULTI SPEED GEAR BOX REAR BEARING PLATE	1
19	71940010	GEAR BOX REAR PLATE	1
20	10260456	HEX HEAD BOLT M8X1.25X30	6
21	10070064	SPACER BUSH DRIVE SHAFT	1
22	10250032	SPUR GEAR 16T -6S	1
23	10250010	SPUR GEAR 17T -6S	1
24	10020097	SPLIT PIN LOCK 1/8 2.5 INCH	1
25	10280093	CASTLE NUT M30X1.5	2
26	10250025	BEVEL GEAR 25T-14S	1
27	10050009	BEARING 32211	1
28	10010002	OIL SEAL 55X80X10	1
29	10070066	TRANSMISSION SHAFT BUSH 21MM	1
30	10290052	TRANSMISSION SHAFT 1408S 1.00 MTR	1
	10290051	TRANSMISSION SHAFT 1408S 1.25 MTR	
	10290050	TRANSMISSION SHAFT 1408S 1.50 MTR	
	10290049	TRANSMISSION SHAFT 1408S 1.75 MTR	
	10290048	TRANSMISSION SHAFT 1408S 2.00 MTR	
31	10040046	GASKET BIG FLANGE TRANSMISSION PIPE	1
32	10260396	HEX HEAD BOLT M10X1.5X30	16
33	73820002	TRANSMISSION PIPE ASSEMBLY 1.00 MTR	1
	73920002	TRANSMISSION PIPE ASSEMBLY 1.25 MTR	
	73830002	TRANSMISSION PIPE ASSEMBLY 1.50 MTR	
	73840002	TRANSMISSION PIPE ASSEMBLY 1.75 MTR	
	73850002	TRANSMISSION PIPE ASSEMBLY 2.00 MTR	
34	10050013	BEARING 32209	1
35	10280010	BREATHER NUT M22X1.5	1
36	10190001	BREATHER VALVE	1
37	10300122	DIP STICK	1
38	10300118	DRAIN PLUG	1
39	10250041	SPUR GEAR 14T -6S (1000 RPM)	1
40	10250042	SPUR GEAR 22T -6S (1000 RPM)	1

REGULAR MULTISPEED (13X25) GEAR BOX ASSEMBLY

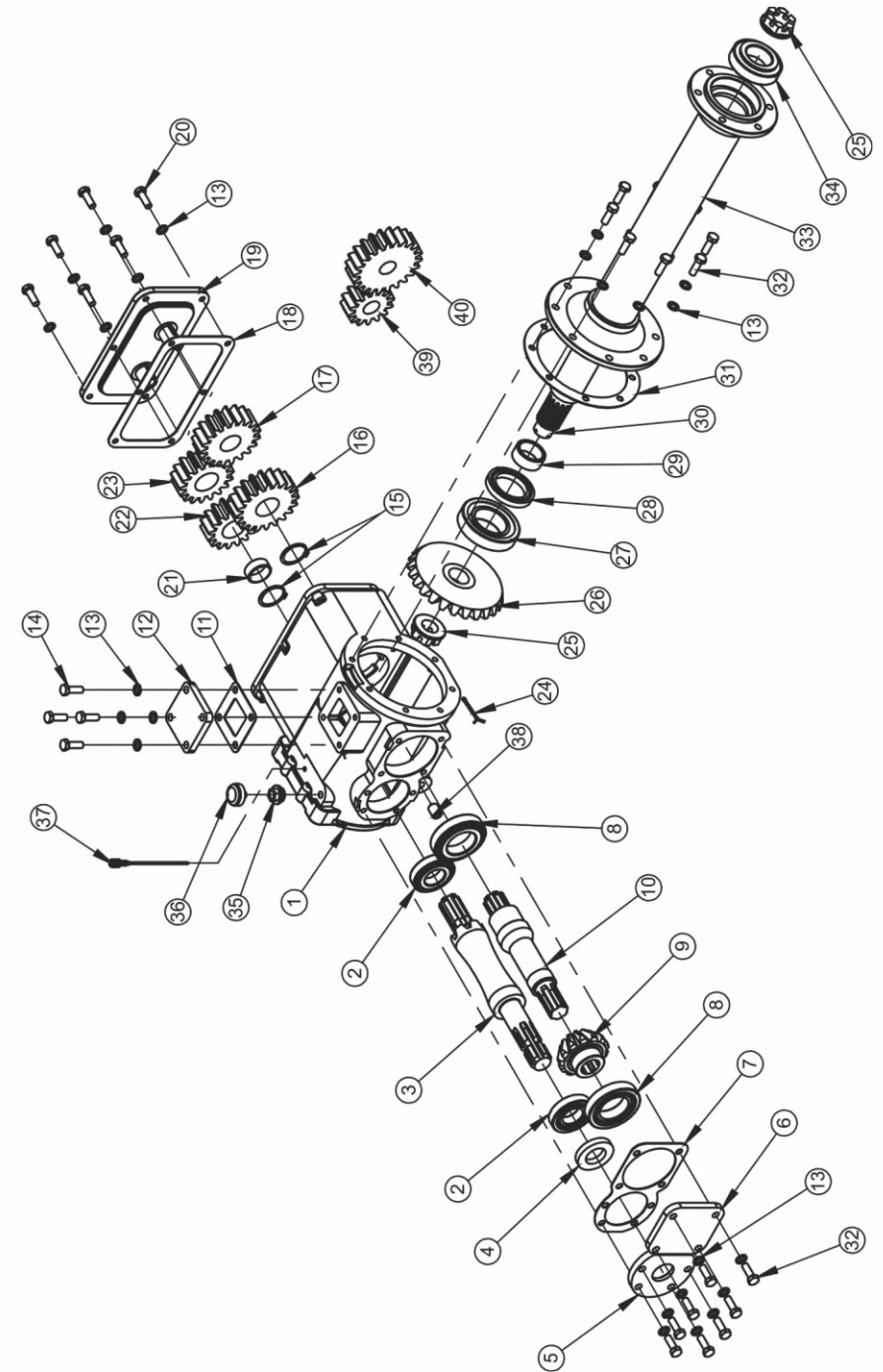

ROBUST SINGLE SPEED GEAR BOX ASSEMBLY (14X25)			
SL. NO.	PART CODE	PART DESCRIPTION	QTY.
1	10080005	ROBUST GEAR BOX HOUSING	1
2	10290023	PINION SHAFT (ROBUST)	1
3	70090007	ROBUST GEAR BOX REAR BEARING PLATE	1
4	70090008	ROBUST GEAR BOX TOP PLATE	1
5	10250024	PINION GEAR 14 TEETH, 8 SPLINES	1
6	10250022	BEVEL GEAR 25 TEETH, 8 SPLINES	1
7	10040037	ROBUST GASKET BIG FLANGE	1
8	10040061	ROBUST GASKET TOP PLATE	1
9	10300118	DRAIN PLUG	1
10	10260408	HEX BOLT M12X20X1.5	1
	10190001	BREATHER VALVE	1
TRANSMISSION SHAFT			
11	10290060	TRANSMISSION SHAFT 1.50 MTR.	1
	10290030	TRANSMISSION SHAFT 1.75 MTR.	1
	10290061	TRANSMISSION SHAFT 2.00 MTR.	1
	10290046	TRANSMISSION SHAFT 2.25 MTR.	1
12	10010005	OIL SEAL 40X80X10	1
13	10010065	OIL SEAL 60X80X10	1
14	10390005	CIRCLIP 80 MM	1
15	10050050	BEARING 30211	1
16	10050087	BEARING 30208	1
17	10050088	BEARING 33112	1
18	10050013	BEARING 32209	1
19	10280093	CASTLE NUT M30X1.5	2
20	10020097	SPLIT PIN /8 2.5"	2
21	10260396	HEX BOLT M10X30X1.5	4
22	10270002	SPRING WASHER M10	12
23	10270002	SPRING WASHER M10	4
24	10260361	HEX HEAD BOLT M10X25X1.5	4
25	10260353	HEX HEAD BOLT M10X35X1.5	8
TRANSMISSION PIPE ASSEMBLY			
26	74380008	TRANSMISSION PIPE ASSEMBLY 1.50 MTR.	1
	73960001	TRANSMISSION PIPE ASSEMBLY 1.75 MTR.	1
	74380009	TRANSMISSION PIPE ASSEMBLY 2.00 MTR.	1
	74380001	TRANSMISSION PIPE ASSEMBLY 2.25 MTR.	1
27	73620006	BREATHER NUT WITH DEEP STICK ASSEMBLY	1
28	10390007	CIRCLIP 100MM	1

ROBUST SINGLE SPEED GEAR BOX ASSEMBLY (14X25)

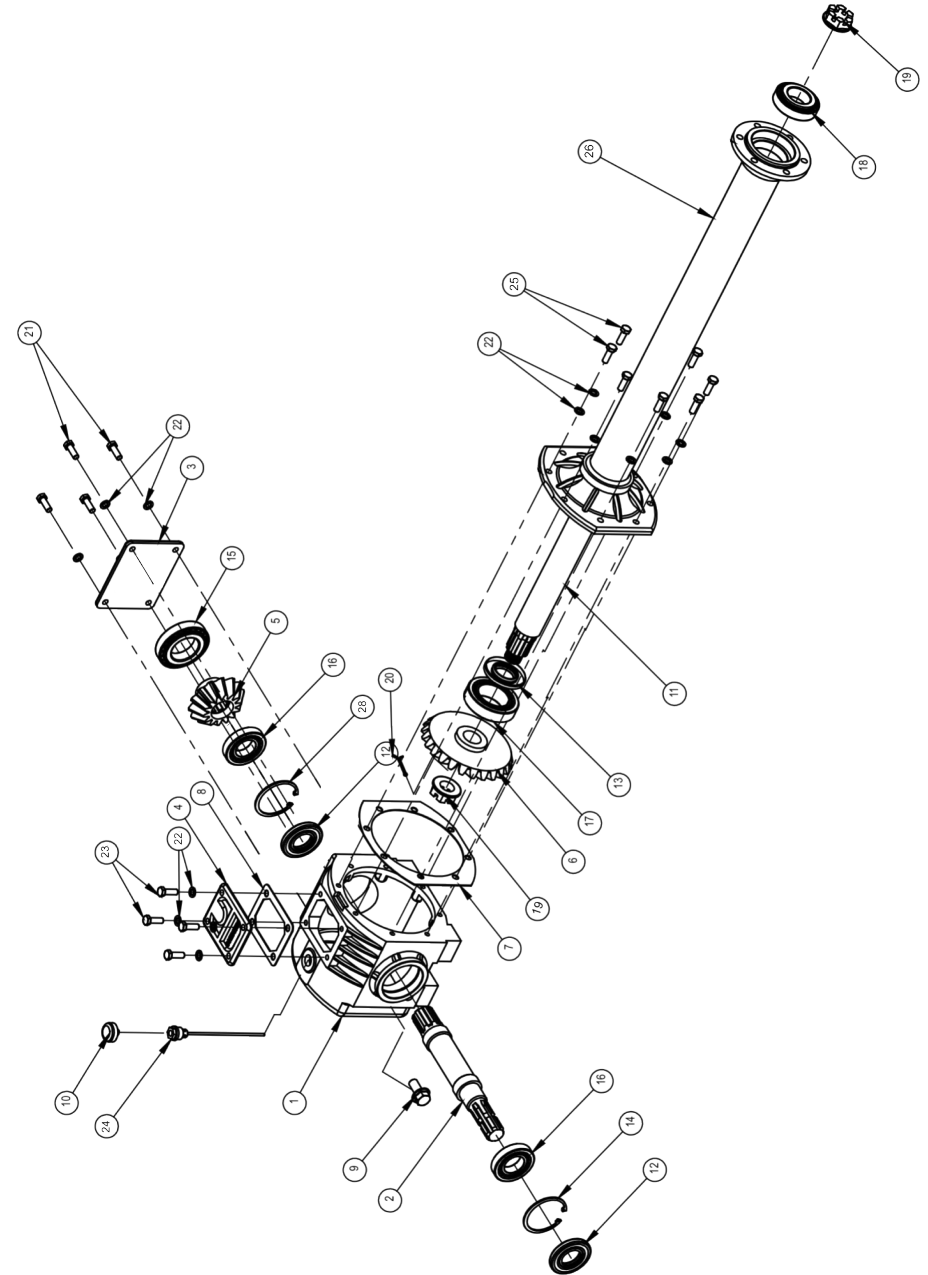

ROBUST (14x25) MULTI SPEED			
SL. NO.	ERP CODE	PART DESCRIPTION	QTY
1	10080007	GEAR BOX HOUSING MULTISPEED	1
2	70090008	MS GEAR BOX TOP PLATE	1
3	10270002	SPRING WASHER M10	18
4	10260361	HEX HEAD BOLT M10X1.5X25	4
5	10390015	EXTERNAL CIRCLIP 42 MM	2
6	10050018	BEARING 30209	1
7	10290045	DRIVE SHAFT 402 MM LENGTH	1
8	10050021	BEARING 32208	1
9	10260396	HEX HEAD BOLT M10X1.5X30	6
10	10010005	OIL SEAL 40X80X10	1
11	70090009	ROBUST M.SPEED FRONT BEARING PLATE	1
12	10050050	BEARING 30211	1
13	10250024	PINION GEAR 14 TEETH/8 SPLINES	1
14	10290044	PINION SHAFT 287 MM LENGTH	1
15	10070062	SPLINED BUSH PINION SHAFT 8 SPLINES	1
16	10300118	DRAIN PLUG	1
17	10050050	BEARING 30211	1
18	10020097	SPLIT PIN LOCK 1/8 X 2.5INCH	2
19	10280093	CASTLE NUT 30X1.5	1
20	10250022	BEVEL GEAR 25 TEETH-8 SPLINES	1
21	10050088	BEARING 33112	1
22	10010065	OIL SEAL 60X80X10	1
23	10040037	GASKET BIG FLANGE MS	1
		TRANSMISSION SHAFT	
	10290072	TRANSMISSION SHAFT 1.25 MTR.	1
	10290056	TRANSMISSION SHAFT 1.50 MTR.	1
	10290057	TRANSMISSION SHAFT 1.75 MTR.	1
	10290058	TRANSMISSION SHAFT 2.00 MTR.	1
	10290059	TRANSMISSION SHAFT 2.25 MTR.	1
	10290062	TRANSMISSION SHAFT 2.50 MTR.	1
	10290063	TRANSMISSION SHAFT 2.75 MTR.	1
		TRANSMISSION PIPE ASSEMBLY	
	74380016	TRANSMISSION PIPE ASSEMBLY 1.25 MTR.	1
	74380010	TRANSMISSION PIPE ASSEMBLY 1.50 MTR.	1
	74380011	TRANSMISSION PIPE ASSEMBLY 1.75 MTR.	1
	74380012	TRANSMISSION PIPE ASSEMBLY 2.00 MTR.	1
	74380013	TRANSMISSION PIPE ASSEMBLY 2.25 MTR.	1
	74380014	TRANSMISSION PIPE ASSEMBLY 2.50 MTR.	1
	74380015	TRANSMISSION PIPE ASSEMBLY 2.75 MTR.	1
24	10050013	BEARING 32209	1
25	10280093	CASTLE NUT 30X1.5	1
26	10260353	HEX HEAD BOLT M10X1.5X35	8
27	10250047	SPUR GEAR 20 TEETH 8 SPLINE	1
28	10250046	SPUR GAER 19 TEETH 8 SPLINE	1
29	10150018	ROBUST BACK COVER PLATE GEAR BOX HOUSING	1
30	10270001	SPRING WASHER M8	6
31	10260360	HEX HEAD BOLT M8X1.5X25	6
32	10250045	SPUR GAER 17 TEETH-8SPLINE	1
33	10250044	SPUR GEAR 16 TEETH-8SPLINE	1
34	10290042	SPACER DRIVE SHAFT ROBUST MULTI	2
35	10040061	GASKET TOP PLATE	1
36	10300120	ROBUST DIP STICK	1
37	10390005	INTERNAL CIRCLIP B80	1
38	10390007	CIRCLIP 100MM	1
39	10390032	CIRCLIP 85 MM	1
40	10250043	SPUR GAER 14 TEETH 8 SPLINE	1
41	10250048	SPUR GAER 22 TEETH 8 SPLINE	1

ROBUST MULTI SPEED GEAR BOX ASSEMBLY

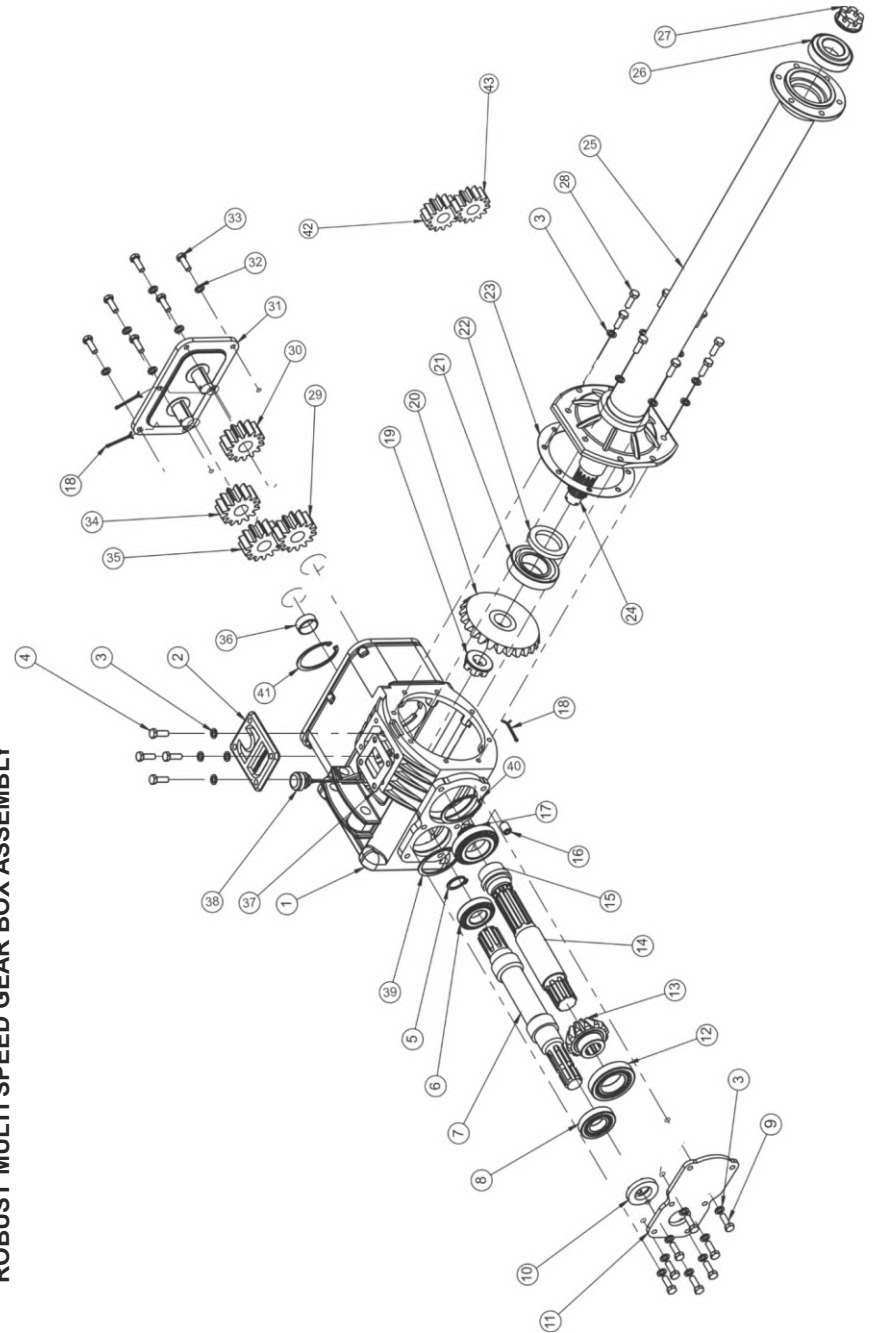

SR. NO.	DESCRIPTION	ITEM CODE			QTY.
		1.75 MTR	2.00 MTR	2.25 MTR	
1	HOPPER ASSEMBLY	10301192	10301193	10301194	1
2	HOPPER BEARING 205 SEED DRILL	10050352			2
3	SPROCKET 28T SUB-ASSEMBLY (DISC SEED DRILL)	10170075			2
4	CHAIN TIGHTNER ASSEMBLY WITH SPROCKET 16T (DISC SEED DRILL)	10170073			1
5	SEED PISTOL MOUNTING ROD SUB-ASSEMBLY FRONT	10160106			1
6	SEED PISTOL MOUNTING ROD SUB-ASSEMBLY REAR	10160107			1
7	BEARING HOUSING SUB-ASSEMBLY	10301270			1
8	CHAIN (48 LINKS)	10140054			1
9	BIG CHAIN COVER ASSEMBLY	10150097			1
10	SHAFT	10290157			1
11	SMALL CHAIN-COVER	10150098			1
12	BEARING 6206	10050020			6
13	DRIVE WHEEL ASSEMBLY	78800271			1
14	SPROCKET 14T	10170080			1
15	DRIVE WHEEL AXLE SUPPORT ASSEMBLY	10290158			1
16	COMPLETE PISTOL ASSEMBLY (FOR SEED) REAR FACE	10670014		16	20
17	FLEXIBLE PVC WATER SUCTION HOSE PIPE 36 O/D X 31 I/D (SEED DRILL)	10200056		16	20
18	CHAIN-41 LINK	10140050			1
19	CASTLE NUT M30X1.5M	10280093			1
20	SPLIT PIN 1/8X2 INCH	10020097			1
21	CONNECTOR	10301197			1
22	SUPPORT ATTACHMENT	10301198			1
23	HEX HEAD BOLT 10X35X1.5 MM	10260353			2
24	HEX HEAD BOLT M8X25X1.25MM	10260360			3
25	PLASTIC HANDLE (SEED DRILL COVER)	78840015			1
26	GAUGE SHEET (LHS) (SEED-CUM-SEED)	78390039			1
27	STOPPER ROD	10160108			1
28	GAUGE SHEET (RHS) (SEED-CUM-SEED)	78390040			1
29	HOPPER COVER ASSEMBLY	78390041	78390042	78390043	1

Roto Seed Drill Hopper Assembly

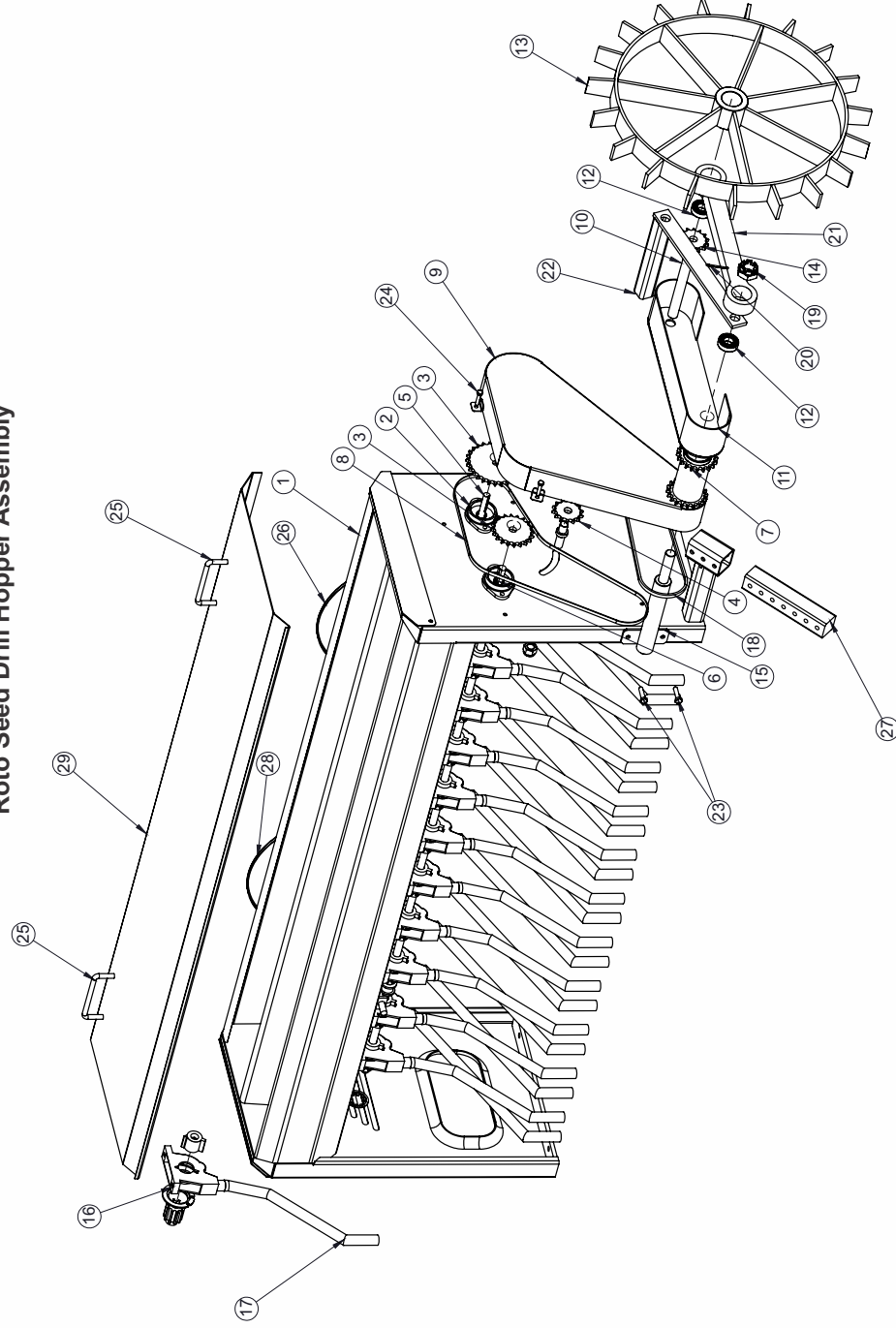

PTO SHAFT ASSEMBLY - SLIP CLUTCH TYPE (10310062)
(Optional)

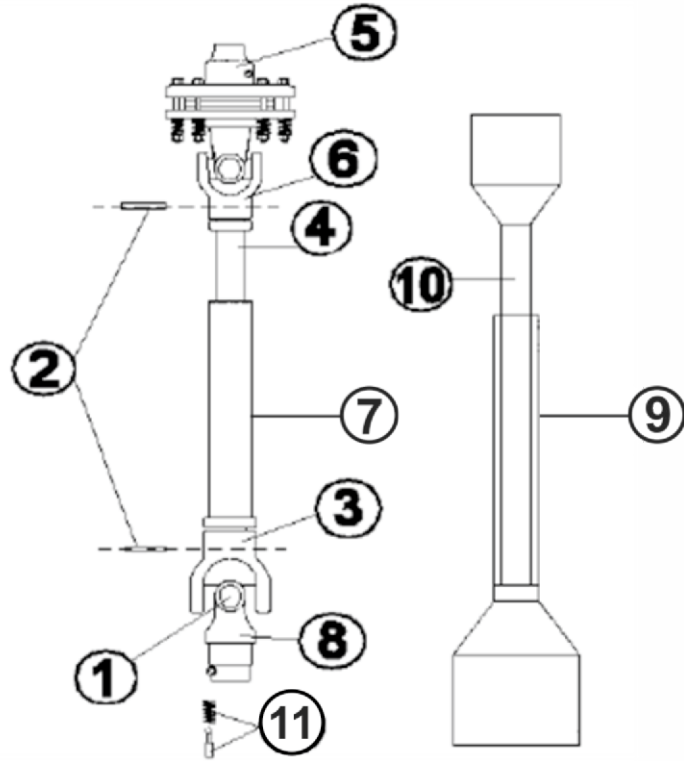

S.No.	DESCRIPTION	Item Code Cut	Quantity
1	CROSS JOURNAL SET	10310003	2
2	SPRING DOWEL PIN SET (SLIP CLUTCH PTO)	10210031	2
3	OUTER TUBE YOKE	10310004	1
4	INNER TUBE (CUT PTO)	10310039	1
5	SLIP CLUTCH ASSEMBLY	10310127	1
6	INNER TUBE YOKE	10310009	1
7	OUTER TUBE (CUT PTO)	10310040	1
8	PUSH PIN YOKE WITH PIN (6 SPLINES)	10310002	1
9	HALF FEMALE GUARD ASSY. (CUT)	10310048	1
10	HALF MALE GUARD ASSY. (CUT)	10310049	1
11	PUSH PIN SET	10310015	1

SLIP CLUTCH ASSEMBLY (10310127)

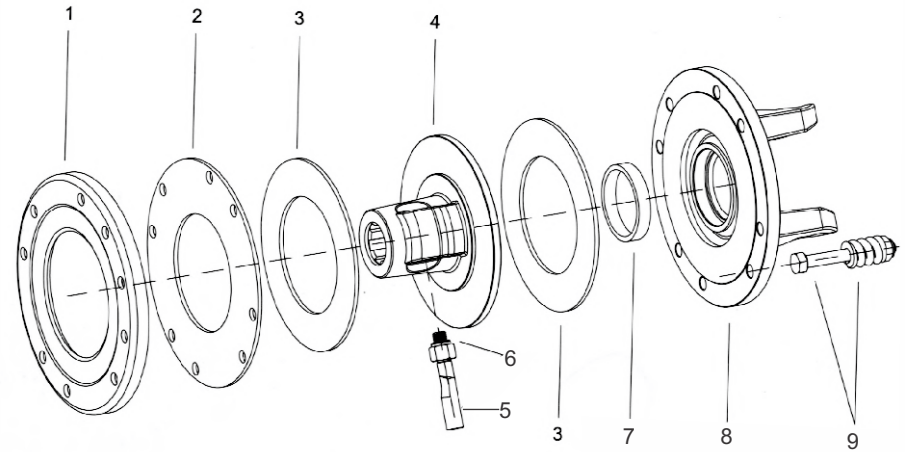

SLIP CLUTCH ASSEMBLY(10310127)			
SR.NO.	PART NAME	ITEM CODE	QTY
1	PRESSURE PLATE	10310128	1
2	INTERNAL DISC	10310129	1
3	FRICION LINING	10310130	2
4	HUB	10310131	1
5	HUB BOLT M12X70X1.75P	10260407	2
6	NYLOCK NUT M12X1.75P	10280025	2
7	BUSHING	10310132	1
8	FLANGED SPLINE	10310133	1
9	COMPLETE BOLT & SPRING	10310134	8

SIDE DISC ASSEMBLY (78960001)			
SR. NO.	DESCRIPTION	ITEM CODE	QTY.
1	HEX BOLT M8X20X1.25	10260188	6
2	SIDE DISC HUB FRONT COVER	10150007	2
3	CASTLE NUT M30X1.5	10280012	1
4	BEARING 32307	10050008	2
5	SIDE DISC HUB	10090001	1
6	OIL SEAL 40X80X10	10010005	1
7	SIDE DISC HUB BACK COVER	10150008	1
8	NYLOCK NUT M10X1.5MM	10280002	3
9	SPRING WASHER 10MM	10270002	3
10	SIDE DISC HUB AXLE (COMPLETE SET)	10110001	1
11	PLAIN DISC 14 INCH (SIDE DISC RT)	10240001	1
12	CSK BOLT M10X30X1.5MM	10260051	3
13	SIDE DISC MOUNTING PIPE ASSEMBLY	73460001	1
14	HEX HEAD BOLT 12X20X1.75MM (10.9 GRADE)	10260057	4
15	PIN 19X90MM	10020026	1
16	LINCH PIN 10MM	10020022	1
17	SIDE DISC ATTACHMENT FRAME ASSEMBLY	73450001	4
18	U-CLAMP 100X62X12	10220028	2
19	SPRING WASHER 12MM	10270003	4
20	NYLOCK NUT M12X1.5(P)	10280003	4

SIDE DISC ATTACHMENT ASSEMBLY

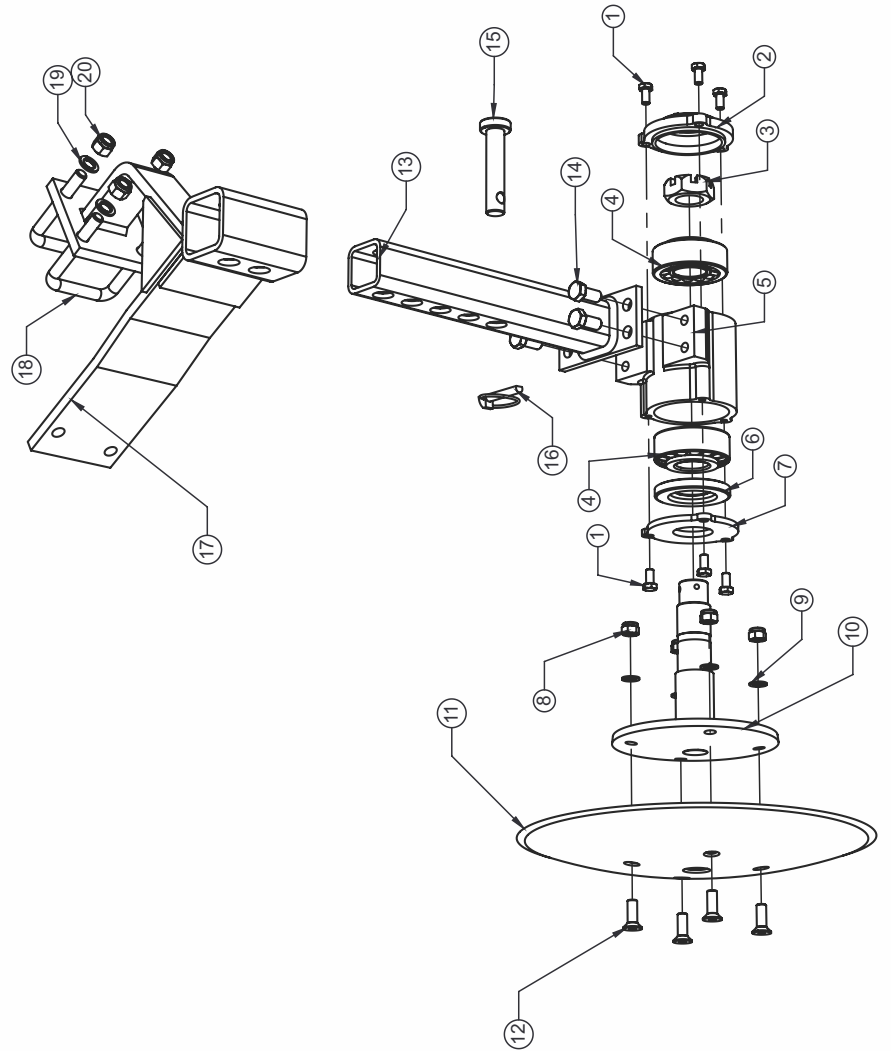

Rotary Tiller PTO Shaft

Sr No.	Description	Part Code			
		540 RPM		1000 RPM	
		CUT	FULL	CUT	FULL
1	PTO PUSH PIN YOKE WITH PIN - 38.05.10B (12X10)	10310059	10310060	10310083	10310084
2	PTO CROSS JOURNAL SET-38.01	10310073		10310075	
3	PTO OUTER TUBE YOKE -38			10310065	
4	DOWEL PIN 10X80 MM			10310097	
5	INNER TUBE	10310039		10020118	
6	OUTER TUBE	10310040			
7	PTO INNER TUBE YOKE -38			10310096	
8	PTO COMPLETE SHEAR BOLT ASSEMBLY (6SPLINE)- 38SBT (12X10)	10310011		10310071	
9	GUARD RETAINING COLLAR FOR OUTER TUBE	10310012			
10	GUARD RETAINING COLLAR FOR INNER TUBE	10310013			
11	SAFETY CHAINS	10310014	10310047	10310014	10310047
12	COMPLETE GUARD ASSEMBLY			10310077	
13	PTO PUSH PIN SET-14X69 (Small)			10310078	
14	PTO PUSH PIN SET-14X91 (Big)			10310030	
15	YOKE FOR B02			10310017	
16	BALL 5/16"			10310042	
17	HUB B02				
18	HEX HEAD BOLT M10X65X1.5MM SAFETY BOLT	10260046			
19	NYLOCK NUT M10X1.5MM	10280002			
20	GREASE FITTING	10310019			
21	U-JOINT FOR OUTER TUBE	10310020		10310056	
22	U-JOINT FOR INNER TUBE			10310021	
23	HALF FEMALE GUARD ASSY.	10310048	10310051	10310048	10310051
24	HALF MALE GUARD ASSY.	10310049	10310050	10310049	10310050

PTO ASSEMBLY-SHEAR BOLT TYPE

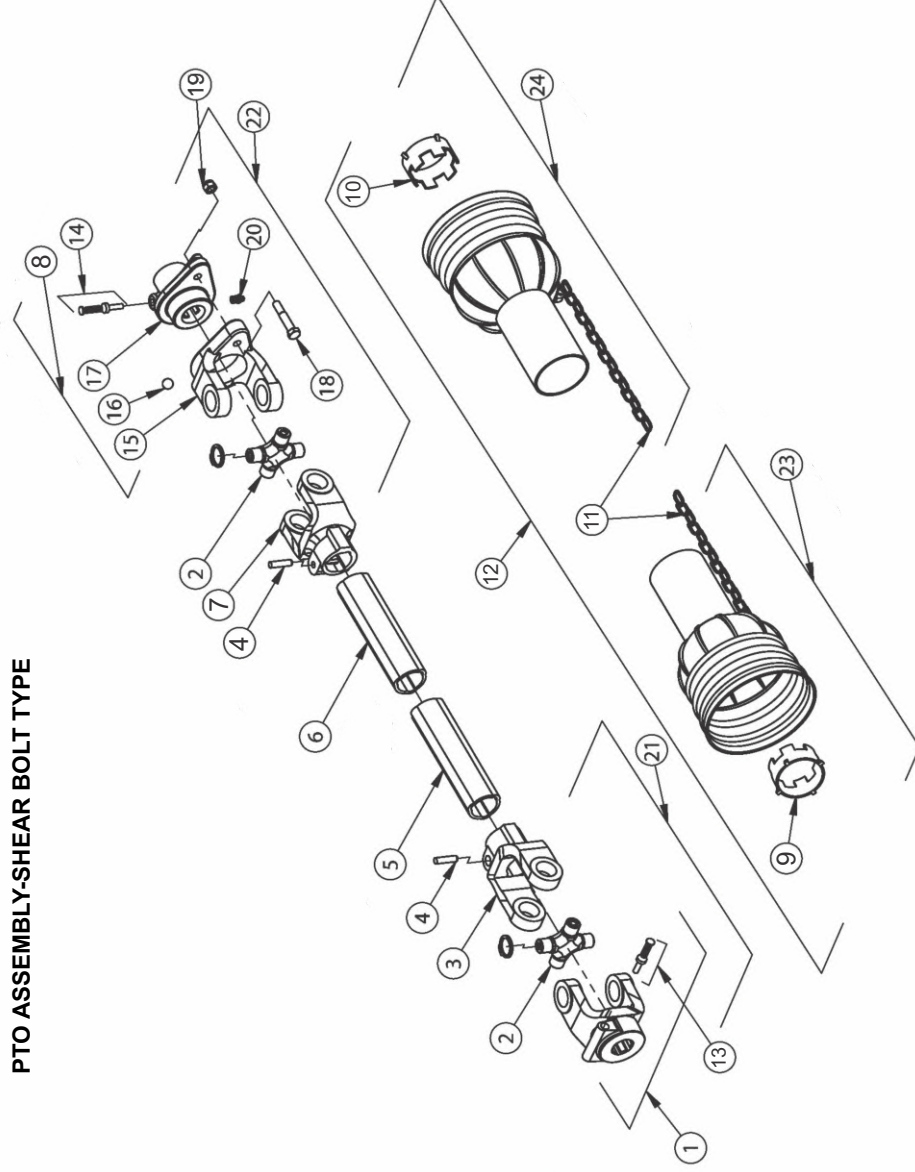

DELIVERY CHECKLIST

Dealer Pre-Delivery (Please Tick)	Please Complete all Dealer information Below
<p>1. Dealer Pre-Delivery Checklist</p> <p>1. The customer or person responsible has been given the operator's manual.</p> <p>2. The customer undertakes to read the complete operator's manual and understands all aspects of the manual before operation of the machine.</p> <p>3. All safety, operational and maintenance information have been explained and demonstrated.</p> <p>4. All greasing and oil points, stickers, guarding and ID plate have been identified and physically pointed out.</p> <p>5. The customer agrees that it is his responsibility to read and carry out the safety, maintenance and operation as per this operator's manual.</p>	<p>Dealer Information</p> <p>Dealer's Name.....</p> <p>Address.....</p> <p>State..... Postcode.....</p> <p>Phone..... Fax.....</p> <p>Email.....</p> <p>Service Person.....</p> <p>I confirm that the pre-delivery service was performed on this machine.</p> <p>Signature.....</p> <p>Date.....</p> <p>Comments.....</p>
Customer Delivery (Please Tick)	Please Complete all Customer Information Below
<p>2. Customer Delivery Checklist</p> <p>1. The customer or person responsible has been given the operator's manual.</p> <p>2. The customer undertakes to read the complete operator's manual and understands all aspects of the manual before operation of the machine.</p> <p>3. All safety, operational and maintenance information have been explained and demonstrated.</p> <p>4. All greasing and oil points, stickers, guarding and ID plate have been identified and physically pointed out.</p> <p>5. The customer agrees that it is his responsibility to read and carry out the safety, maintenance and operation as per this operator's manual.</p>	<p>Customer Information</p> <p>Customer's Name.....</p> <p>Address.....</p> <p>State..... Postcode.....</p> <p>Phone..... Fax.....</p> <p>Email.....</p> <p>Delivery Person.....</p> <p>I confirm that all of the delivery checks were explained and performed.</p> <p>Signature.....</p> <p>Delivery Date.....</p> <p>Comments.....</p>



WARRANTY CARD Customer Copy

CUSTOMER NAME Mr./ Mrs :	
ADDRESS :	
MOBILE NO. :	
Email :	
NAME OF IMPLEMENT :	
MODEL NO. :	
YEAR OF Mfg. :	
SERIAL NO. :	
REGISTRATION NO. :	
DATE OF PURCHASING :	
NAME OF DEALER :	
Customer's Signature	Dealer's Signature

FIELDKING USA, INC.

960 Holmdel Road Suite 2-02, Holmdel, NJ 07733, USA
 ✉ exports@fieldking.com, 🌐 www.fieldking.com

FIELDKING

USA

WARRANTY CARD

Dealer Copy

CUSTOMER NAME Mr./ Mrs :

ADDRESS :

MOBILE NO. :

Email :

NAME OF IMPLEMENT :

MODEL NO. :

YEAR OF Mfg. :

SERIAL NO. :

REGISTRATION NO. :

DATE OF PURCHASING :

NAME OF DEALER :

Customer's Signature

Dealer's Signature

FIELDKING USA, INC.

960 Holmdel Road Suite 2-02, Holmdel, NJ 07733, USA

✉ exports@fieldking.com, 🌐 www.fieldking.com

FIELDKING

USA

WARRANTY CARD

Company Copy

CUSTOMER NAME Mr./ Mrs :

ADDRESS :

MOBILE NO. :

Email :

NAME OF IMPLEMENT :

MODEL NO. :

YEAR OF Mfg. :

SERIAL NO. :

REGISTRATION NO. :

DATE OF PURCHASING :

NAME OF DEALER :

Customer's Signature

Dealer's Signature

FIELDKING USA, INC.

960 Holmdel Road Suite 2-02, Holmdel, NJ 07733, USA

✉ exports@fieldking.com, 🌐 www.fieldking.com