

FIELDKING

USA

**Mounted Offset Disc Harrow
(Regular Series)**

**Mounted Offset Disc Harrow
(Hunter Series)**



➤ [Operator Manual](#) ➤ [Service Manual](#) ➤ [Part Catalogue](#)

CONGRATULATIONS!

You have invested in one of the best implements of its type in the market today.

The care you give your “FIELDKING USA” implement will greatly determine your satisfaction with its performance and its service life. A careful study of this manual will give you a thorough understanding of your new implement before operating.

If your manual is lost or destroyed, “FIELDKING USA” will be glad to provide you a new copy. Visit to nearest dealership & get a copy. Most of our manuals can also be downloaded from our website at www.fieldkingusa.com.

As an authorized “FIELDKING USA” dealer, we stock genuine “FIELDKING USA” parts which are manufactured with the same precision and skill as our original equipment. Our trained service persons are well informed on methods required to service “FIELDKING USA” equipments and are ready to help you.

Should you require additional information or assistance, please contact us.

YOUR AUTHORIZED

FIELDKING USA DEALER

BECAUSE “FIELDKING USA” MAINTAINS AN ONGOING PROGRAMME OF PRODUCT IMPROVEMENT, WE RESERVE THE RIGHT TO MAKE IMPROVEMENTS IN DESIGN OR CHANGE IN SPECIFICATION WITHOUT INCURRING ANY OBLIGATION TO INSTALL THEM ON UNITS PREVIOUSLY SOLD. BECAUSE OF THE POSSIBILITY THAT SOME PHOTOGRAPHS IN THIS MANUAL WERE TAKEN OF PROTOTYPE MODELS, PRODUCTION MODELS MAY VARY IN SOME DETAIL. IN ADDITION, SOME PHOTOGRAPHS MAY SHOW SHIELDS REMOVED FOR THE PURPOSE OF CLARITY. NEVER OPERATE THIS IMPLEMENT WITHOUT ALL SHIELDS IN PLACE.

TO THE PURCHASER

This manual contains valuable information about your new “FIELDKING USA” mounted offset disc harrow. It has been carefully prepared to give you helpful suggestions for operating, adjusting, servicing and ordering spare parts.

Keep this manual in a convenient place for quick and easy reference. Study it carefully. You have purchased a dependable and sturdy mounted offset disc harrow but only by proper care and operation you can expect to receive the service and long life designed and built into it.

Sometime in the future your mounted offset disc harrow may need new parts to replace those that are worn or broken. If so, go to your dealer and provide him equipment’s detail like model and part number.

CUSTOMER INFORMATION

Name _____

Purchased From _____

Date of Purchase _____

Model No. _____

Serial No. _____

PURCHASER / OPERATOR’S RESPONSIBILITY

1. Read and understand the information contained in this manual.
2. Operate, lubricate, assemble and maintain the equipment in accordance with all instructions and safety procedures in this manual.
3. Inspect the equipment and replace or repair any parts that are damaged or worn out which under continued operation would cause damage, wear to other parts, or cause a safety hazard.
4. Return the equipment or parts to the authorized “FIELDKING USA” dealer, from where it was purchased, for service or replacement of defective parts that are covered by warranty. (The “FIELDKING USA” Factory may inspect equipment or parts before warranty claims are honored.)
5. All costs incurred by the dealer for traveling to or transporting the equipment for warranty inspection and claims will be borne by the customer.

INDEX

1. TECHNICAL DATA

- 1.1 Introduction
- 1.2 Warranty
- 1.3 When the warranty becomes void
- 1.4 Warning

2. USAGE INSTRUCTIONS

- 2.1 Before use & adjustments
- 2.2 Attaching harrow to the tractor
- 2.3 Warning for driver
- 2.4 Safety

3. MAINTENANCE

- 3.1 Maintenance Instructions
- 3.2 Storage of machine after work
- 3.3 Lubrication
- 3.4 Instruction for driver

4. OPERATIONAL GUIDELINES FOR HARROW

5. TROUBLE SHOOTING CHART

1. TECHNICAL DATA

1.1 INTRODUCTION

This handbook contains the use and maintenance instructions with a list of the spare parts of the disc harrow.

This disc harrow is equipped with heavy-duty channel frame specially designed for harrowing / land preparation of rough soil (secondary finer operation).

Regular and satisfactory operation together with economic and long lasting use of the implement depends on the compliance with instructions given in this handbook.

Compliance with the instructions in this handbook is also important since manufacturer declines all and every responsibility for damage to persons or property caused by negligence and failure to comply with these instructions.

1.2 WARRANTY

When the machine is delivered, check that it has not been subjected to damage during transport and that the accessories are in a perfect condition and complete.

Any claims following the receipt of damaged goods shall be presented in writing within 8 days from the receipt of the goods.

The purchaser may only make the claims under warranty when he has complied with the warranty conditions in the supply contract.

1.3 WHEN THE WARRANTY BECOMES VOID

- Besides the cases specified in the supply agreement, the warranty shall in any case become void.
- When the implement has been used beyond the specified power limit like (tractor horse power)
- When repairs made by the customer without authorization from the manufacturer or owing to installation of spurious spare parts, the machine is subjected to variations and the damage can be ascribed to these variations.
- When the user has failed to comply with the instructions in this handbook.
- If the implement is used in very hard/stony soil no warranty of discs will be given.
- No warranty will be given if the service and greasing is not done on time.

1.4 WARNING

- Thoroughly read the instruction manual before proceeding with the various operations.
- Maintain the harrow as per the instructions of this handbook to be entitled for warranty.

2. USAGE INSTRUCTIONS

2.1 BEFORE USE & ADJUSTMENTS

1. Before mounting of disc harrow make sure that all nuts & bolts are properly secured.
2. Also determine soil and trash conditions of the field and make the preliminary adjustments. e.g.

a) Disc gang angle adjustment

Gang angle (Angle between two gangs) ranges between 40° to 50°. The angle can be increased for better penetration in dry soil while it should be reduced to avoid clogging in wet soil.

b) Disc harrow leveling

To eliminate uneven penetration and side draft, leveling is done by means of top link. While tractor pulls to right the rear gang should be lowered a little. When the tractor pulls to the left the rear gang should be raised.

c) Scraper adjustment

The scraper can be adjusted by loosening the bolts at the scraper clamp.

d) Depth control

The depth at which the implement is required to work is controlled hydraulically by raising or lowering the control lever on the tractor.

e) Disc harrow penetration

Factors affecting disc harrow penetration are

1. Angle of the gang
2. Weight of the harrow
3. Disc diameter
4. Disc sharpness (Blunt disc increases the draft considerably, check the disc sharpness)
5. Angle of hitch

- #### f) Greasing nipple position during operation should be as shown in figure.

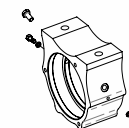

IMPORTANT NOTE : TO AVOID FROM DUST & MUD THIS GREASE NIPPLE DIRECTION SHOULD BE IN REAR SIDE OF BOTH FRONT AND REAR GANG DURING FIELD OPERATION

2.2 ATTACHING THE HARROW TO THE TRACTOR

1. Place the harrow duly leveled on the flat piece of land.
2. Reverse the tractor to the harrow (Do not drag the harrow up the tractor).
3. Attach the left arm of the tractor to the harrow first.
4. Attach the central arm to the harrow. To attach, turn the screws on both sides to an equal length. If the arm is too short or too long, turn the screw to adjust both at the same time until aligned with the hole on the central arm.
5. Attach the lower right arm, turn the screw until the mounting pin is at the same level as the hole on the tractor arm. If the gap between the hole and mounting pin is too close or too distant, turn the control arm in or pull it away to an appropriate distance. You may have to adjust both height and distance at the same time. When the hole at tractor arm and mounting pin are even, insert the pin in the hole and lock it with the lynch pin.
6. After attaching the harrow, lift it and adjust the control arm parallel to the ground. When you look from both rear or sideways, the discs should all be touching the ground uniformly.

2.3 WARNING FOR THE DRIVER

1. Before harrowing check all nuts & bolts of the disc harrow.
2. Be vigilant about the tree roots and stones. Don't harrow on stony soil.
3. Tractor should be in first high or fourth low gear.
4. Don't allow anyone to come across the harrow.
5. Lift the disc harrow on every turn.
6. Lift the harrow before approaching the road.

1.4 SAFETY

Understanding the Machine Safety Labels



Safety-Alert Symbol

The machine safety labels shown in this section are placed in important areas on your machine to draw attention to potential safety hazards

On your machine the words DANGER, WARNING and CAUTION are used with this safety-alert symbol. DANGER identifies the most serious hazards.

The operator's manual also explains any potential safety hazards whenever necessary.

► Before harrowing with disc harrow take care that nobody stands near it.



In order to protect yourself always wear adequate clothes and shoes during the operations.



Never allow riders on the tractor or implement unless an additional seat is available.

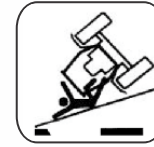

Be careful when moving around steep gradient to avoid sharp turn.

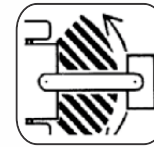

Never transport the implement on rough roads during the night. When operating, avoid sharp turns that may cause tractor colliding with the implement.

3. MAINTENANCE

3.1 MAINTENANCE INSTRUCTIONS

If you work the disc harrow on stony land then maintenance also increases.

1. If the soil has entered the grease nipple, then change the nipple.
2. After initial working of first two hours, tighten all nuts & bolts.
3. After every fifty hours grease all greasing points with grease gun and tighten all nuts & bolts.
4. After fifty hours, open the bearing hub/bearing spool of disc harrow & cleanse with diesel oil & pump in new grease.

3.2 STORAGE OF MACHINE AFTER WORK

1. Wash the disc harrow after work.
2. Replace the worn out nuts & bolts.
3. If disc harrow has to remain unused for long time then clean it & apply a layer of used oil for rust prevention.

These steps will enhance the life of your disc harrow.

3.3 LUBRICATION

Please take care that high quality grease is used in bearing hub.

3.4 INSTRUCTIONS FOR DRIVER

1. When disc harrow is ready for use don't stand between disc harrow & the tractor.
2. Properly fit the three point linkage as mentioned above & lock with lynch pin.
3. In case of scraper touching the discs, loosen the scraper bolt and readjust the scraper.
4. Never turn the tractor to the right or left when the harrow is engaged in the soil.
5. Never reverse the tractor when the harrow is engaged in the soil.
6. To get good results from the harrow, disc should be replaced when its diameter is reduced by 5" from its original size.

4. OPERATIONAL GUIDELINES FOR HARROW

1. Lift the harrow on turning for effective independent breaking of soil.
2. Adjust internal /external check chains to obtain implement swing range within 50 mm (2") when raised.
3. Always maintain the correct tyre pressure to avoid wheel slippage.
4. Adding of wheel weights/water ballasting or combination of both is recommended when excessive rear wheel slippage is experienced.
5. Always set hydraulic levers correctly for draft and position control operation.

The following settings are necessary to ensure that uniform working depth is maintained

a.) Side draft

The mounted offset disc harrow will trail correctly behind the tractor provided the side thrust of the front gang is equal to that of rear. In case it is different there will be side draft. To set it correctly the gang angle should be changed.

b.) Severe Side Draft

In case of severe side draft the cutting depth of rear disc gang should be increased or decreased with the help of tractor top link. For instance when tractor pulls to right, lower the rear gang and when tractor pulls to left, raise the rear gang.

Precautions during transportation

1. When transporting the harrow, shorten top link to minimum length.
2. Set hydraulic levers in top raised position and lock levers.
3. Maintain the speed to avoid jumps.
4. Watch while overtaking on road.
5. Always use SMV (Slow moving vehicles) symbols.



Dear user!
Respect the Ecology.
Do not throw the trash away.
This gesture helps to protect our Environment.

5. TROUBLE SHOOTING CHART

SR. NO.	POSSIBLE CAUSES	POSSIBLE REMEDIES
A. Side Draft		
1.	Disc not running level	Adjust using leveling lever
2.	Gangs improperly angled	Set the gangs
3.	Too much left hand offset.	Swing the hitch to the left
B. Excessive field slippage		
1.	Tractor overloaded	Reduce angle, reduce depth
2.	Not enough tractor ballast	Add wheel weight or liquid
C. Not filling the furrow		
1.	Too much left hand offset	Swing hitch to the left
2.	Tractor wheel running in furrow enlarging it	Drive the tractor in unworked ground
3.	Disc too far from furrow	Keep the left front discs in furrow
4.	Rear gang set wrong, laterally.	Move the rear gang right or left. The rear gang disc should be centered in the space between front discs
D. Poor penetration		
1.	Hard ground	Swing hitch to the right. Increase angle in front and rear gang
E. Disc unsteady		
1.	Too much angle in gang	Reduce the gang angle
F. Gang clogging		
1.	Field too wet.	Disc at shallow depth for first pass to speed up drying process
2.	Gang set in maximum angle.	Reduce the angle
3.	Not using scrapers	Install scrapers
4.	Scrapers worn out or not set properly.	Replace worn ones. Adjust scrapers close to the disc
5.	Discing too deep in damp soil	Reduce penetration

MOUNTED OFFSET DISC HARROW 6x6 TO 12x12 (REGULAR SERIES)

SR.NO.	DESCRIPTION	PART NO.						QTY.
		6x6	7x7	8x8	9x9	10x10	11x11	
1	MAIN FRAME ASS.	71040009	72810001	72810001	72860001	73000001	73000001	1
2	FRONT CHANNEL ASS.	72020001			72820001			1
3	HITCH PIN 20MM			10020013				2
4	SPRING WASHER 25MM			10270007				3
5	NYLOCK NUT M25			10280008				3
6	3-POINT LINKAGE ASS.			71070010				1
7	U-CLAMP 120.5CD			10220009			3	4
8	HEX HEAD BOLT M16x105x2P			10260134				1
9	SPRING WASHER 16MM			10270005			3	4
10	NYLOCK NUT M16X2P			10280005			3	4
11	HEX HEAD BOLT M18x75x2.5P			10260375				2
12	PLAIN WASHER 18MM			10270021				2
13	SPRING WASHER 18MM			10270006				2
14	NYLOCK NUT M18x2.5P			10280006				2
15	LEVER BUSH ASS.			72030001				1
16	HEX NUT M12x45x1.72P			10260427				1
17	SPRING WASHER 12MM			10270003				1
18	NYLOCK NUT M12x1.75P			10280003				1
19	CLAMP ADJUSTMENT ROD ASS.			720040001				1
20	ADJUSTMENT ROD	71070004			71070009			1
21	ADJUSTMENT ROD HANDLE			72040002				1
22	SQ. BUSH			71070006				1
23	BRACKET SQ. BUSH			71070005				1
24	HEX HEAD BOLT M16x50x2P			10260078				2
25	LINTCH PIN 10MM			10020022				1
26	PLAIN NUT M20x25L			10280055			14	16
27	SPRING WASHER 20MM			10270016			14	16
28	U-CLAMP 113 CD.			10220012				3
29	UCLAMP 127.5 CD.			10220011				1
30	CLAMP PLATE			71040007			3	4

MOUNTED OFFSET DISC HARROW (REGULAR SERIES)

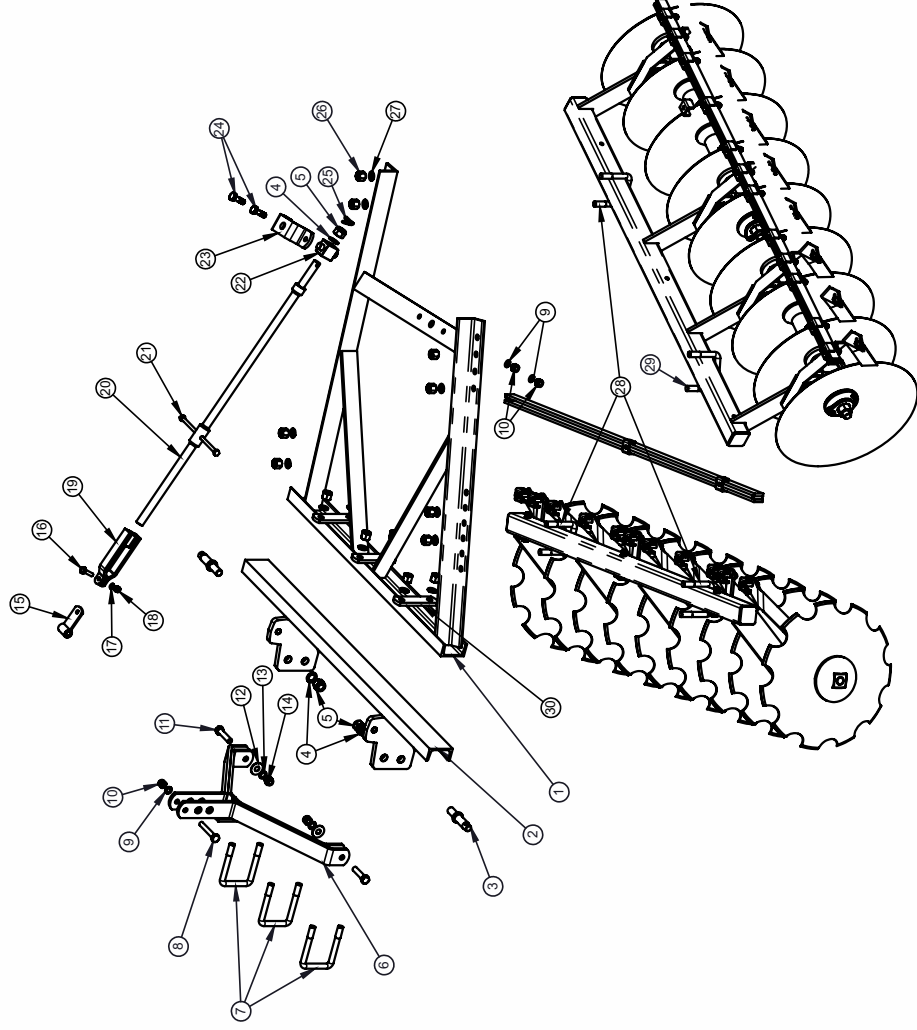

FRONT GANG ASSY. WITH GANG BOX & SCRAPER (REGULAR SERIES)

SR. NO.	DESCRIPTION	PART NO.							QTY.						
		6x6	7x7	8x8	9x9	10x10	11x11	12x12	6x6	7x7	8x8	9x9	10x10	11x11	12x12
1	FRONT GANG BOX ASS.	71080003	71050008	71100003	71120003	71140003	73000001	74000001							
2	SCRAPER FRONT GANG				79940003				5	6	7	8	9	10	11
3	SCRAPER HOLDING FLAT ASSY.	71080005	71080006	71080007	71080008	71080009	71080010	71080011							
4	HEX HEAD BOLT M12x70x1.75P				10260407				7	8	10	11	12	14	15
5	SPRING WASHER 12MM				10270003				9	10	13	14	15	18	19
6	NYLOCK NUT M12X1.75P				10280003				2			3			4
7	L-STRIP				71050007				2			3			4
8	HEX BOLT M12x100x1.75P				10260448				2			3			4
9	HEX HEAD BOLT M16x50x2P				10260358				4	6					8
10	SPRING WASHER 16MM				10270005				8	12					16
11	NYLOCK NUT M16x2P				10280005				4	6					8
12	NOTCHED DISC 22" SQ.HOLE 30MM				10240024				6	7	8	9	10	11	12
13	CHAPPEN BIG				10360003				1						2
14	AXLE ROD ASS.	71090002	71060004	71110002	72850001	71130003	71130003	71090002	1			1	2	1	2
15	AXLE ROD ASS.				71130003							1		1	
16	BEARING HUB ASS.				72060001				2	3					4
17	HUB ANGLE				71060003				2	3					4
18	PLAIN WASHER 16MM				10270020				4	6					8
19	PLAIN SPOOL (4.4 Kg)				10340004				3	4		3	4	5	6
20	HEX HEAD BOLT M16x40x2P				10260120				4	6					8
21	DISC WASHER (5")				71060002				1						2
22	SMALL CHAPPEN (GANG LOCK)				10360002				1						2
23	PLAIN NUT 28MM 7G BSW				10280014										2
24	GANG LOCK PLATE				71050009										2
25	HEX HEAD BOLT M10X25x1.5P				10260158				7	8	10	11	12	14	15
26	SCRAPER HOLDING CLAMP				77840003										

FRONT GANG ASSY. WITH GANG BOX & SCRAPER (REGULAR SERIES)

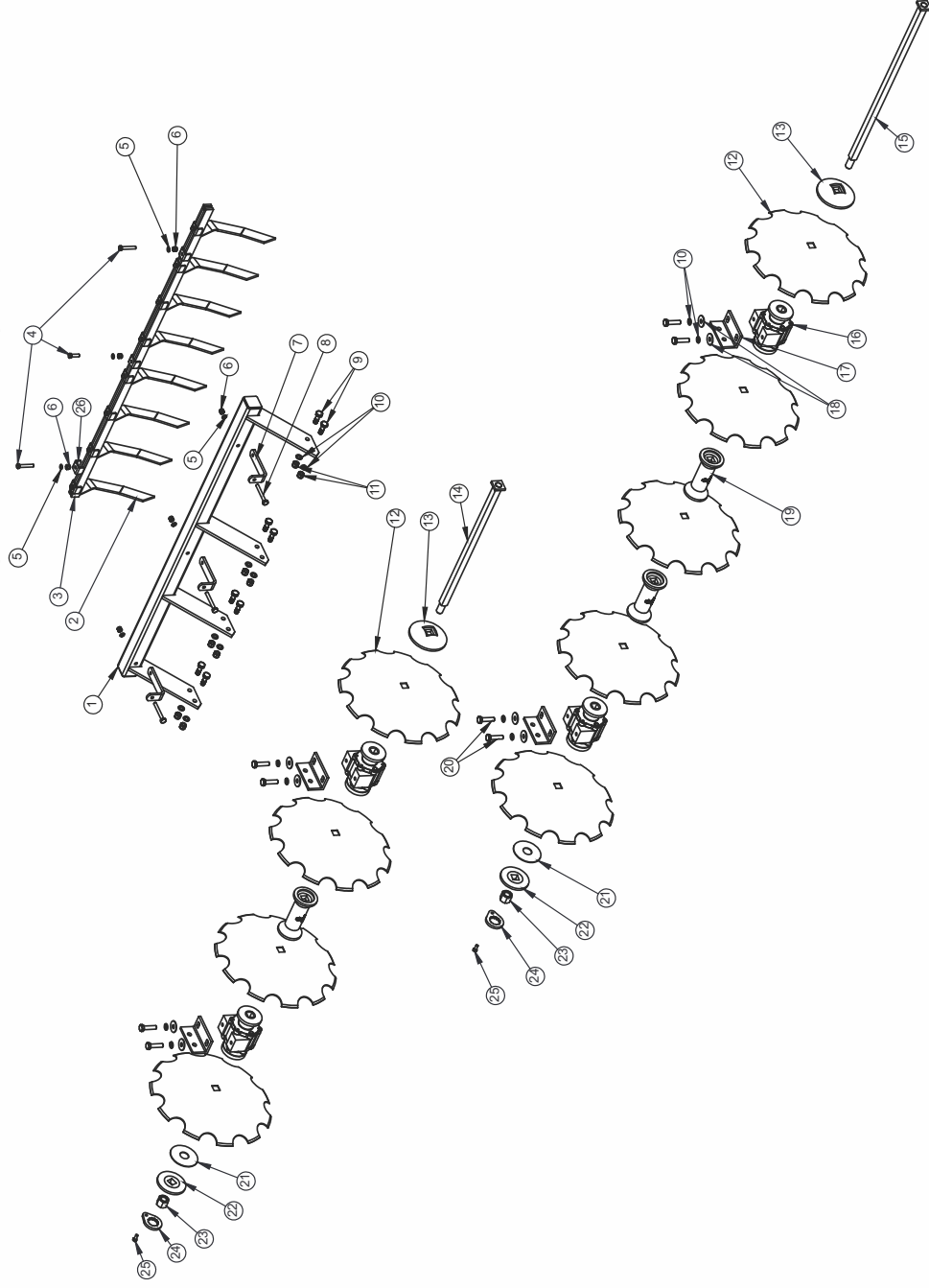

REAR GANG ASSY. WITH GANG BOX & SCRAPER

SR.NO.	DESCRIPTION	PART NO.						QTY.							
		6x6	7x7	8x8	9x9	10x10	11x11	12x12	6x6	7x7	8x8	9x9	10x10	11x11	12x12
1	REAR GANG BOX ASS.	72050001	72080001	72830001	72840001	72870001	72880001	75100001							
2	HEX BOLT M16x50x2p				10260358				4	6	8				
3	SCRAPER BAND ANGLE ASS.				72070001				2	3	4				
4	HEX BOLT M12x70x1.75P				10260407				7	8	10	11	12	14	
5	SCRAPER HOLDING FLAT REAR	71080005	71080006	71080007	71080008	71080009	71080010	71080011							
6	SCRAPER REAR GANG				79940004				5	6	7	8	9	10	
7	SPRING WASHER 12MM				10270003				9	10	13	14	15	18	
8	NYLOCK NUT M12x1.75P				10280025				9	10	13	14	15	18	
9	HEX BOLT 16x40x2P				10260120				4	6	8				
10	SPRING WASHER 16MM				10270005				8	12	16				
11	PLAIN WASHER 16MM				10270020				4	6	8				
12	PLAIN DISC 22" SQ HOLE 30MM				10240021				6	7	8	9	10	11	
13	CHAPPEN BIG				10360003				1					2	
14	AXLE ROD ASS.	71090002	71060004	71110002	72850001	71130003	71130003	71090002	1			1	2	1	
15					71130003							1	1		
16	HUB ANGLE				71060003				2	3	4				
17	BEARING HUB ASS.				72060001				2	3	4				
18	PLAIN SPOOL (4.4 Kg)				10340004				3	4	3	4	5	6	
19	DISC WASHER (5")				10340004				1					2	
20	SMALL CHAPPEN (GANG LOCK)				10360002				1					2	
21	PLAIN NUT 28MM 7G BSW				10280014				2					4	
22	NYLOCK NUT M16x2P				10280005				4	6	8				
23	GANG LOCK PLATE				71050009									2	
24	HEX HEAD BOLT M10X25X1.5P				10260158									2	
25	SCRAPER HOLDING CLAMP				77840003				7	8	10	11	12	14	

REAR GANG ASSY. WITH GANG BOX & SCRAPER

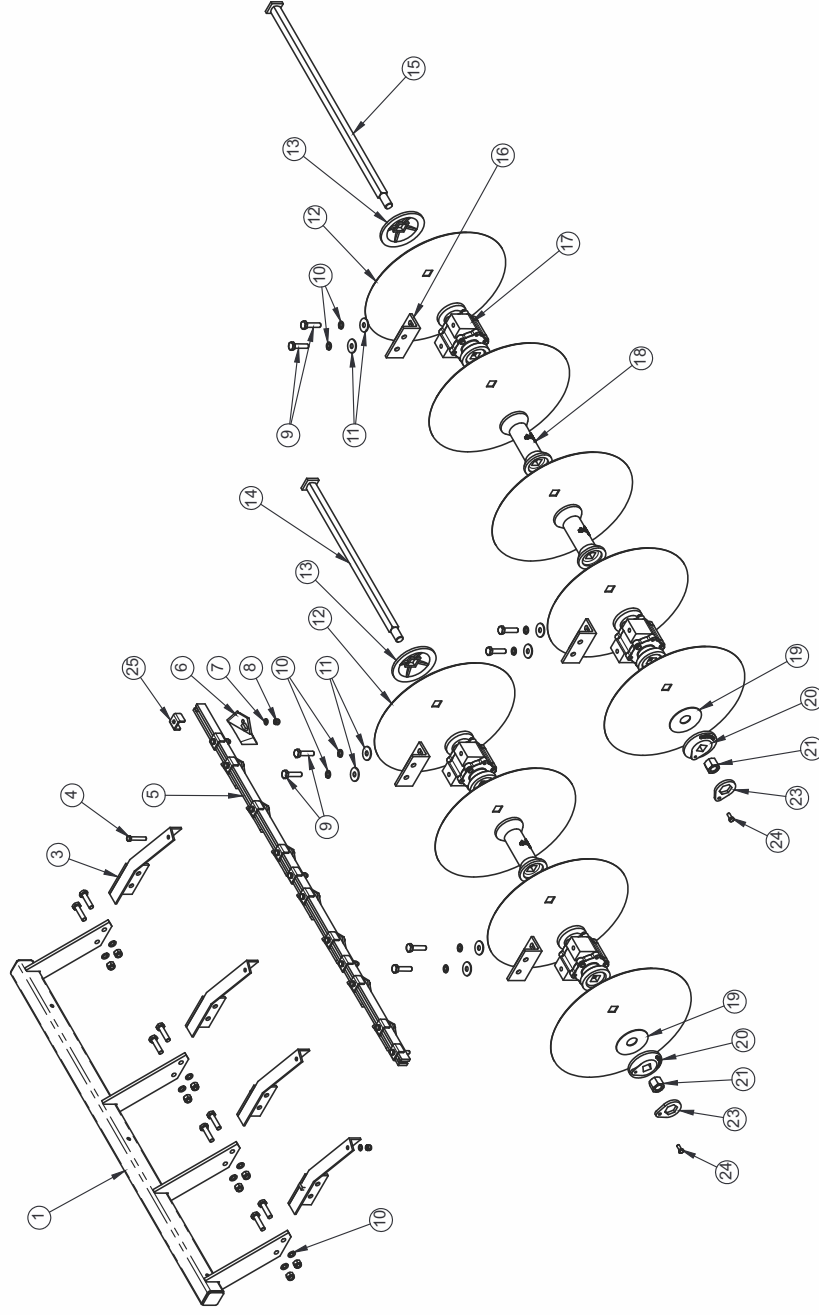

MOUNTED OFFSET DISC HARROW 9x9 TO 13x13 (HUNTER SERIES)

Sr.No.	DESCRIPTION	PART NO.					QTY.						
		9x9	10x10	11x11	12x12	13x13	9x9	10x10	11x11	12x12	13x13		
1	MAIN FRAME ASSEMBLY	71040033			71040010						1		
2	FRONT GANG BOX ASSY.	71120005	71140008	71150005	74000010	74000005					1		
3	REAR GANG BOX ASSY.	71120006	71140009	72880003	75700006	75100008					1		
4	SCRAPER HOLDING FLAT ASSY.	71080008	71080009	71080010	71080011	71080005 71080006	2	4	4	2	2		
5	L-STRIP			71050007			3			4			
6	SCRAPER HOLDING BEND ANGLE			72070001						4			
7	FRONT SCRAPER ASSY.			79940003			8	9	10	11	12		
8	REAR SCRAPER ASSY.			79940004			8	9	10	11	12		
9	SCRAPER HOLDING CLAMP			77840003			23	26	28	30	32		
10	HEX. BOLT M12X1.5PX70L			10260407			23	26	28	30	32		
11	SPRING WASHER 12MM			10270003			26	28	31	33	35		
12	NYLOCK NUT M12x1.75			10280003			26	28	31	33	35		
13	HEX BOLT M20x70Lx2.5P			10260505						8			
14	NYLOCK NUT M20x2.5P			10280021						8			
15	HEX HEAD BOLT M16x2Px110L			10260366						2			
16	SPRING WASHER 16MM			10270005						18			
17	NYLOCK NUT M16x2P			10280005						18			
18	HEX. BOLT M12X1.75X110L			10260477						4			
19	HEX HEAD BOLT M16x50x2P			10260358						16			
20	LINCH PIN 10MM			10020022						2			
21	TILLER PIN Ø28x145L WITH HANDLE			10020047						2			
22	EYE BOLT BUSH			10070182						1			
23	EYE BOLT			10260154						1			
24	PLAIN NUT 9/8 EYE BOLT			10280076						1			
25	LEVER SUPPORT PIPE ASSY. 9X9 TO 10X10 / 11X11 TO 13X13			71040027 / 71040038						1			

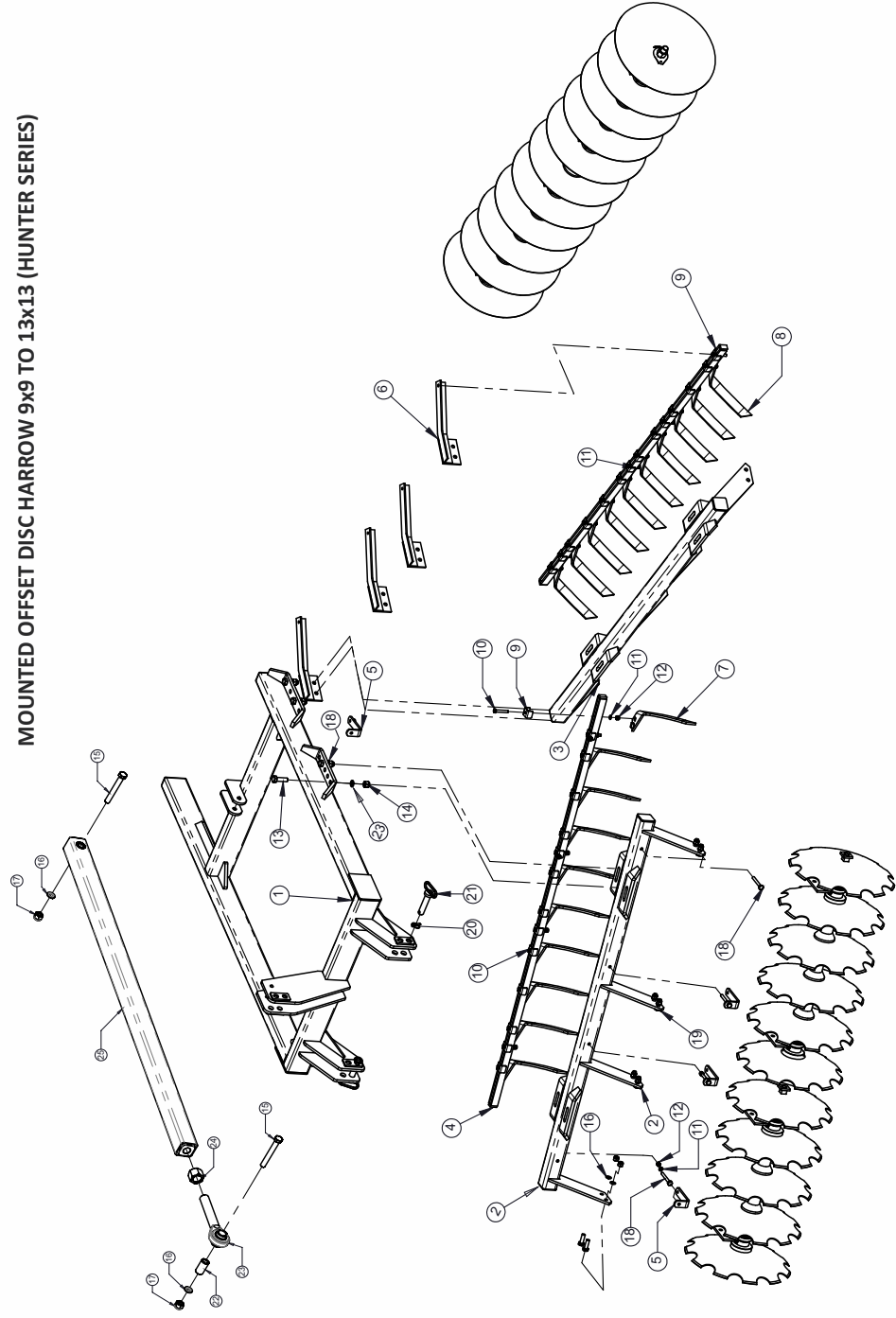

MOUNTED OFFSET DISC HARROW 9x9 TO 13x13 (HUNTER SERIES)

FRONT & REAR DISC GANG ASSEMBLY (HUNTER SERIES)

Sr.No.	DESCRIPTION	PART NO.							QTY.				
		9x9	10x10	11x11	12x12	13x13	9x9	10x10	11x11	12x12	13x13		
1	AXLE ROD ASSEMBLY (32MM)	72850004 (4-Disc)	71130004 (5-Disc)	71130004 (5-Disc)	71090006 (6-Disc)	71060006 (7-Disc)	2	4	2	4	2		
		71130004 (5-Disc)		71090006 (6-Disc)	71090006 (6-Disc)	71090006 (6-Disc)	2		2		2		
2	BEARING HUB ASSY. (34MM SQ.)	72060004							8				
3	HEX BOLT M16x40x2P	10260120							16				
4	SPRING WASHER 16MM	10270005							16				
5	PLAIN WASHER 16MM	10270020							10				
6	NOTCHEDPLAIN DISC 22" SQ. HOLE 34MM	10240083 / 10240082							9/9	10/10	11/11	12/12	13/13
7	BIG CHAPPEN (NUT LOCK TYPE)	10360018							4				
8	HUB ANGLE	71060003							8				
9	PLAIN SPOOL	10340024							6	8	10	12	14
10	DISC WASHER	71060002							4				
11	SMALL CHAPPEN (GANG LOCK)	10360014							4				
12	PLAIN NUT 28MM 7G BSW	10280014							8				
13	GANG LOCK PLATE	71050009							8				
14	HEX HEAD BOLT M10x25x1.5P	10260158							8				
15	SCRAPPER BEND ANGLE ASSEMBLY	72070001							4				

FRONT & REAR DISC GANG ASSEMBLY (HUNTER SERIES)

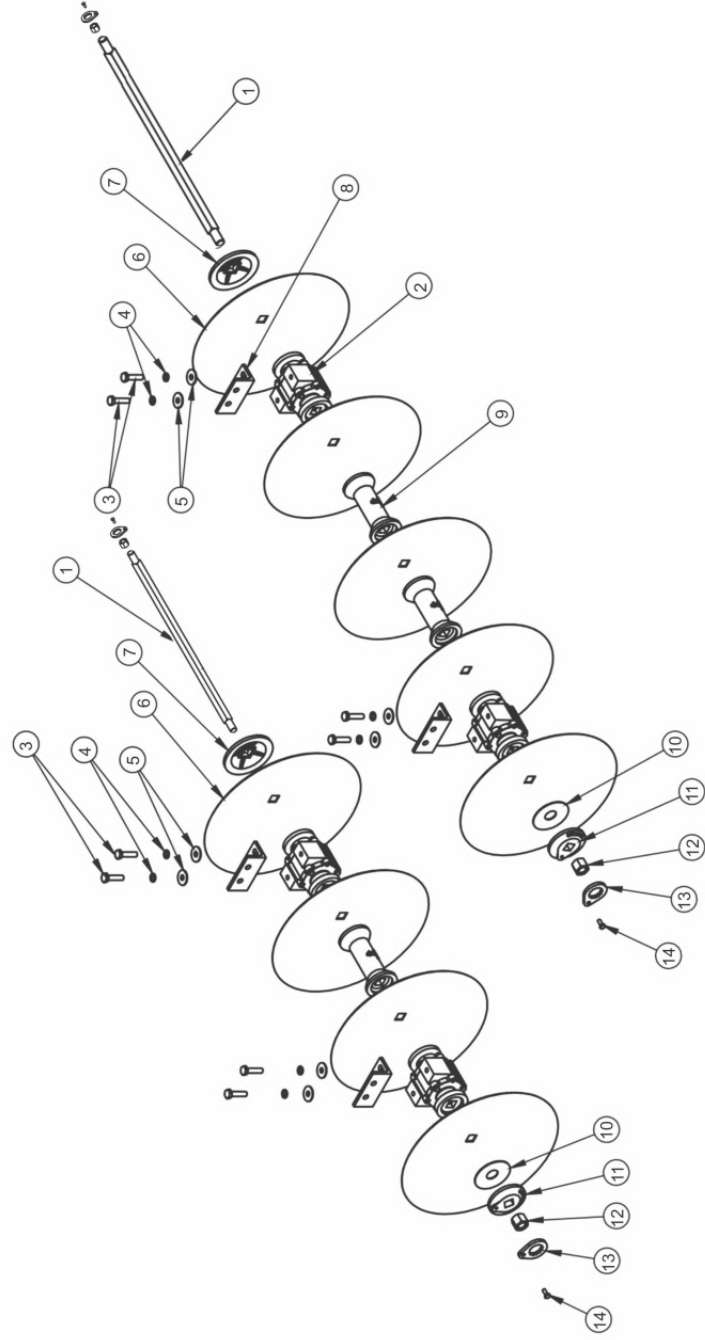

MOUNTED OFFSET DISC HARROW BEARING HUB ASSY. (REGULAR SERIES)

SR. NO.	DESCRIPTION	PART NO.	QTY.
1	BEARING HUB	10090008	1
2	BEARING 30211	10050050	2
3	OIL SEAL 65x85x18T	10010003	2
4	BEARING HUB COVER	10180010	2
5	SPRING WASHER 10MM	10270002	6
6	HEX BOLT M10x35x1.5P	10260053	6
7	BEARING SPOOL	10340003	1
8	CIRCLIP 55MM (EXTERNAL)	10390001	1
9	BEARING SPOOL CAP	10180007	1
10	GREASE NIPPLE 10MM	10300005	1
11	HEX HEAD BOLT M8x16x1.25P	10260779	5
12	SPRING WASHER 8MM	10270001	5
13	HUB SAFETY COVER	10150112	1

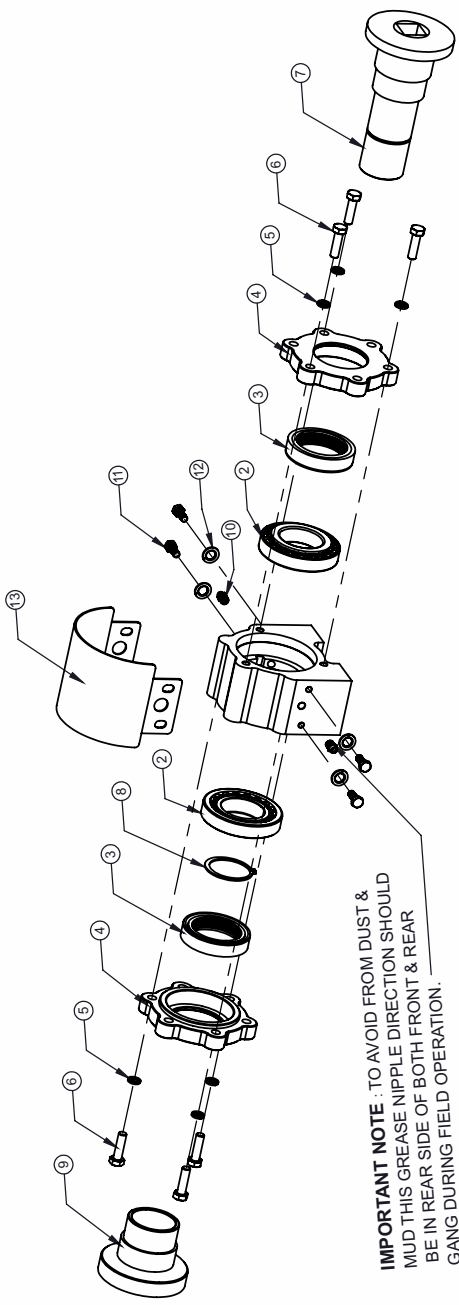

HARROW BEARING HUB ASSY. (HUNTER SERIES)

ITEM NO.	DESCRIPTION	PART NO.	QTY.
1	BEARING HUB	10090083	1
2	BEARING SPOOL	10340023	1
3	BEARING SPOOL CAP	10180034	1
4	BEARING HUB COVER	10180060	2
5	OIL SEAL 70X95X15	10010091	2
6	HEX HEAD BOLT M10x45x1.5P	10260005	6
7	SPRING WASHER 10MM	10270016	6
8	CIRCLIP A60	10390030	1
9	GREASE NIPPLE M10x15x1.5P	10300005	1
10	SPRING WASHER 8MM	10270001	4
11	HEX HEAD BOLT M8x16x1.25P	10260779	5
12	HUB SAFETY COVER	10150099	1
13	TAPER ROLLER BERG. 30212	10050024	2

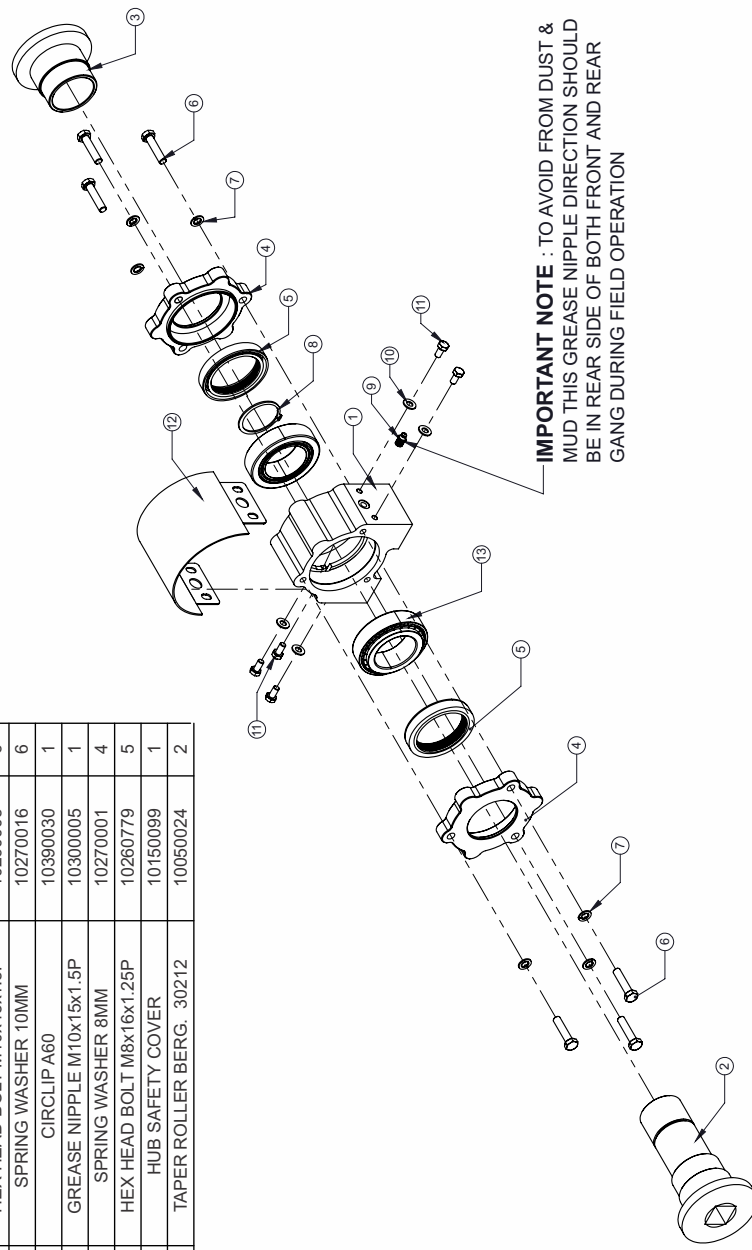

MAIN FRAME HUNTER SERIES (FLEXIBLE LEVER)
9x9 TO 10x10 & 11x11 TO 13x13

ITEM NO.	PART NAME	PART NO.	QTY.
1	MAIN FRAME ASSEMBLY (FLEXIBLE TYPE) 9x9 To 10x10 / 11x11 To 13x13	72810001 / 71040052	1
2	LEVER ASSEMBLY	72840001	1
3	ADJUSTING ROD 9x9 TO 10x10 / 11x11 TO 13x13	71070004 / 10160081	1
4	ADJUSTMENT ROD CLAMP ASSEMBLY	72040001	1
5	LEVER BUSH ASSEMBLY	72030001	1
6	SQUARE BUSH	71070006	1
7	ADJUSTING ROD HANDLE	72040002	1
8	LINCH PIN 10MM	10020022	1
9	NYLOCK NUT M25x3P	10280008	1
10	NYLOCK NUT M16x2P	10280005	2
11	SPRING WASHER 16MM	10270005	2
12	HEX HEAD BOLT M16x120x2P	10260377	1
13	HEX HEAD BOLT M12x50x1.75P	10260363	1
14	SPRING WASHER 12MM	10270003	1
15	NYLOCK NUT M12x1.75P	10280025	1
16	HEX HEAD BOLT M20x80x2P	10260517	2
17	SPRING WASHER 20MM	10270003	2
18	NYLOCK NUT M20x2.5P	10270003	2

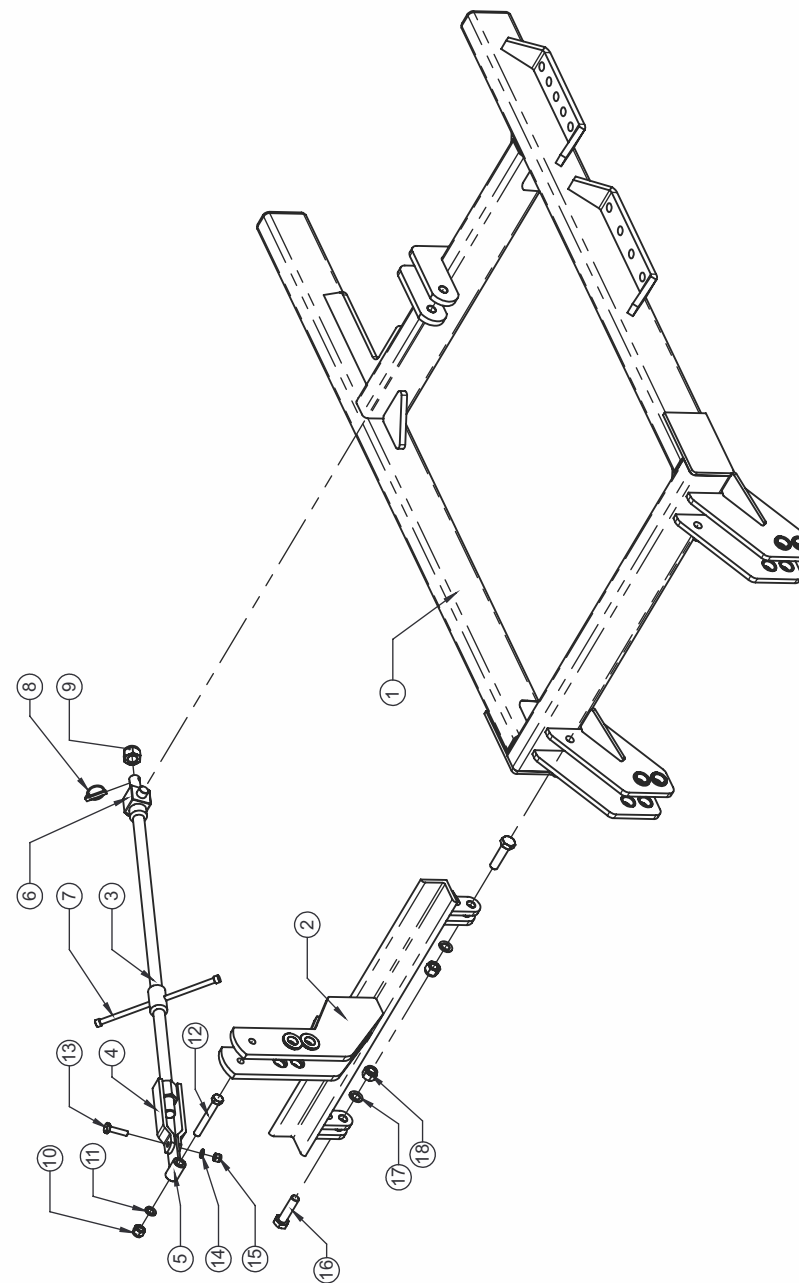

DELIVERY CHECKLIST

Dealer Pre-Delivery (Please Tick)	Please Complete all Dealer information Below
<p>1. Dealer Pre-Delivery Checklist</p> <ol style="list-style-type: none"> 1. The customer or person responsible has been given the operator's manual. 2. The customer undertakes to read the complete operator's manual and understands all aspects of the manual before operation of the machine. 3. All safety, operational and maintenance information have been explained and demonstrated. 4. All greasing and oil points, stickers, guarding and ID plate have been identified and physically pointed out. 5. The customer agrees that it is his responsibility to read and carry out the safety, maintenance and operation as per this operator's manual. 	<p>Dealer Information</p> <p>Dealer's Name.....</p> <p>Address.....</p> <p>State..... Postcode.....</p> <p>Phone..... Fax.....</p> <p>Email.....</p> <p>Service Person.....</p> <p>I confirm that the pre-delivery service was performed on this machine.</p> <p>Signature.....</p> <p>Date.....</p> <p>Comments.....</p>
Customer Delivery (Please Tick)	Please Complete all Customer Information Below
<p>2. Customer Delivery Checklist</p> <ol style="list-style-type: none"> 1. The customer or person responsible has been given the operator's manual. 2. The customer undertakes to read the complete operator's manual and understands all aspects of the manual before operation of the machine. 3. All safety, operational and maintenance information have been explained and demonstrated. 4. All greasing and oil points, stickers, guarding and ID plate have been identified and physically pointed out. 5. The customer agrees that it is his responsibility to read and carry out the safety, maintenance and operation as per this operator's manual. 	<p>Customer Information</p> <p>Customer's Name.....</p> <p>Address.....</p> <p>State..... Postcode.....</p> <p>Phone..... Fax.....</p> <p>Email.....</p> <p>Delivery Person.....</p> <p>I confirm that all of the delivery checks were explained and performed.</p> <p>Signature.....</p> <p>Delivery Date.....</p> <p>Comments.....</p>



WARRANTY CARD Customer Copy

CUSTOMER NAME Mr./ Mrs :	
ADDRESS :	
MOBILE NO. :	
Email :	
NAME OF IMPLEMENT :	
MODEL NO. :	
YEAR OF Mfg. :	
SERIAL NO. :	
REGISTRATION NO. :	
DATE OF PURCHASING :	
NAME OF DEALER :	
Customer's Signature	Dealer's Signature

FIELDKING USA, INC.

960 Holmdel Road Suite 2-02, Holmdel, NJ 07733, USA

✉ usa@fieldking.com, www.fieldkingusa.com

WARRANTY CARD
Dealer Copy

CUSTOMER NAME Mr./ Mrs :

ADDRESS :

MOBILE NO. :

Email :

NAME OF IMPLEMENT :

MODEL NO. :

YEAR OF Mfg. :

SERIAL NO. :

REGISTRATION NO. :

DATE OF PURCHASING :

NAME OF DEALER :

Customer's Signature

Dealer's Signature

FIELDKING USA, INC.

960 Holmdel Road Suite 2-02, Holmdel, NJ 07733, USA

✉ usa@fieldking.com, www.fieldkingusa.com

WARRANTY CARD
Company Copy

CUSTOMER NAME Mr./ Mrs :

ADDRESS :

MOBILE NO. :

Email :

NAME OF IMPLEMENT :

MODEL NO. :

YEAR OF Mfg. :

SERIAL NO. :

REGISTRATION NO. :

DATE OF PURCHASING :

NAME OF DEALER :

Customer's Signature

Dealer's Signature

FIELDKING USA, INC.

960 Holmdel Road Suite 2-02, Holmdel, NJ 07733, USA

✉ usa@fieldking.com,  www.fieldkingusa.com



Tillage



Cultivation



Landscaping



Seeding & Plantation



Harvest



Post Harvest

Solutions...



04-02-2020

FIELDKING USA, INC.

960 Holmdel Road Suite 2-02, Holmdel, NJ 07733, USA

✉ usa@fieldking.com, www.fieldkingusa.com