







-  Tillage
-  Haulage
-  Landscaping
-  Seeding & Plantation
-  Crop Protection
-  Harvest
-  Post Harvest

Solutions...



17-11-2018

FIELDKING
USA

Sub Soiler Heavy Series



FIELDKING USA, INC.

960 Holmdel Road Suite 2-02, Holmdel, NJ 07733, USA

✉ usa@fieldking.com, www.fieldkingusa.com

- [Operator Manual](#)
- [Service Manual](#)
- [Part Catalogue](#)

CONGRATULATIONS!

You have invested in one of the best implements of its type in the market today.

The care you give your "FIELDKING USA" implement will greatly determine your satisfaction with its performance and its service life. A careful study of this manual will give you a thorough understanding of your new implement before operating.

If your manual is lost or destroyed, "FIELDKING USA" will be glad to provide you a new copy. Visit to nearest dealership & get a copy. Most of our manuals can also be downloaded from our website at www.fieldkingusa.com.

As an authorized "FIELDKING USA" dealer, we stock genuine "FIELDKING USA" parts which are manufactured with the same precision and skill as our original equipment. Our trained service persons are well informed on methods required to service "FIELDKING USA" equipments and are ready to help you.

Should you require additional information or assistance, please contact us.

YOUR AUTHORIZED

FIELDKING USA DEALER

BECAUSE "FIELDKING USA" MAINTAINS AN ONGOING PROGRAMME OF PRODUCT IMPROVEMENT, WE RESERVE THE RIGHT TO MAKE IMPROVEMENTS IN DESIGN OR CHANGE IN SPECIFICATION WITHOUT INCURRING ANY OBLIGATION TO INSTALL THEM ON UNITS PREVIOUSLY SOLD. BECAUSE OF THE POSSIBILITY THAT SOME PHOTOGRAPHS IN THIS MANUAL WERE TAKEN OF PROTOTYPE MODELS, PRODUCTION MODELS MAY VARY IN SOME DETAIL. IN ADDITION, SOME PHOTOGRAPHS MAY SHOW SHIELDS REMOVED FOR THE PURPOSE OF CLARITY. NEVER OPERATE THIS IMPLEMENT WITHOUT ALL SHIELDS IN PLACE.

TO THE PURCHASER

This manual contains valuable information about your new "FIELDKING USA" Sub Soiler Heavy Series. It has been carefully prepared to give you helpful suggestions for operating, adjusting, servicing and ordering spare parts.

Keep this manual in a convenient place for quick and easy reference. Study it carefully. You have purchased a dependable and sturdy Sub Soiler Heavy Series but only by proper care and operation you can expect to receive the service and long life designed and built into it.

Sometime in the future your Sub Soiler Heavy Series may need new parts to replace which are worn out or broken. If so, go to your dealer and provide him equipment's detail like model and part number.

CUSTOMER INFORMATION

Name _____

Purchased From _____

Date of Purchase _____

Model No. _____

Serial No. _____

PURCHASER / OPERATOR'S RESPONSIBILITY

1. Read and understand the information contained in this manual.
2. Operate, lubricate, assemble and maintain the equipment in accordance with all instructions and safety procedures in this manual.
3. Inspect the equipment and replace or repair any parts that are damaged or worn out which under continued operation would cause damage, wear to other parts, or cause a safety hazard.
4. Return the equipment or parts to the authorized "FIELDKING USA" dealer, from where it was purchased, for service or replacement of defective parts that are covered by warranty. (The "FIELDKING USA" Factory may inspect equipment or parts before warranty claims are honored.)
5. All costs incurred by the dealer for traveling to or transporting the equipment for warranty inspection and claims will be borne by the customer.

1. INTRODUCTION

1.1 Introduction

2. TECHNICAL INFORMATION

2.1 General description

2.2 Warranty

2.3 When the warranty becomes void

2.4 Warning

3. USAGE INSTRUCTIONS

3.1 Overall check -up

3.2 Attaching sub-soiler to the tractor

3.3 Safety Instruction

4. TRACTOR PREPARATION AND WORKING

4.1 Instructions for tractor preparation

4.2 Width of cut adjustment

4.3 Levelling the sub-soiler

4.4 Adjustments for deeper penetration

4.5 Warning for driver

4.6 Trouble shooting

5. MAINTENANCE

5.1 Maintenance Instructions

5.2 Storage of Machine after work

6. PICTURES AND PART CODE NO. FOR TRACTOR OPERATOR/DRIVER

1. TECHNICAL DATA

1.1 INTRODUCTION

This manual contains the use and maintenance instructions with a list of the spare parts of the FIELDKING USA Sub-Soiler.

"FIELDKING USA" sub-soiler is used to break-up compacted soil layers and open the ground up, so that roots and moisture can penetrate more deeply into the soil. Yields suffer when compaction keeps roots from growing freely throughout the soil in search of moisture and nutrients. Sub-soiler usage lets plants to stretch their roots by opening passageways through the hardpan. It can be used as a primary tillage tool i.e. one used for the first pass over a field but not normally a part of usual tillage operation.

This implement is useful when a plow pan or hard pan (compacted layer) has developed because of regular plowing and disking or heavy animal and equipment traffic. When operated properly in dry soil this implement fractures and shatters the hard soil.

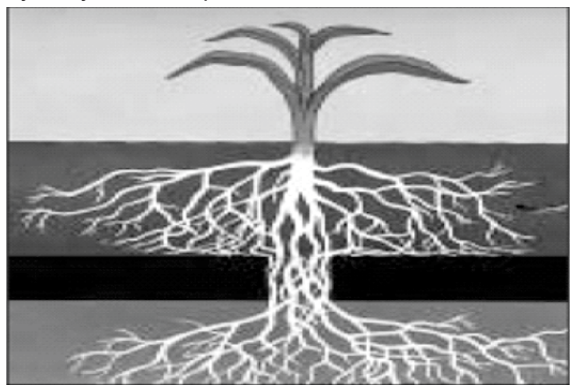

Fig-1 root growth after use of sub-soiler

2. TECHNICAL INFORMATION

2.1 GENERAL DESCRIPTION

BENEFITS

- The sub-soilers are deep tillage implements specially designed for breaking up hard pan layers and loosening the subsoil allowing better drainage, root growth and mineral osmosis.
- The heavy duty chisel pointed share shatters the soil well below the surface, thus increasing the water holding capacity.
- It preserves moisture during high rainfall which is very important for the crop to withstand low rainfall or drought periods.
- It is an inexpensive implement & it provides a simple and economical way to obtain boosting crop yields and profits.

FEATURES

- It can go up to 28 inch deep.

- It fights draught by increasing the ground storage capacity.
- It increases soil turnover by reaching deeper organic matter layers.

2.2 WARRANTY

When the machine is delivered, check that it has not been subjected to damage during transport and that the accessories are in a perfect condition and complete.

Any claims following the receipt of damaged goods shall be presented in writing within 8 days from the receipt of the goods.

The purchaser may only make the claims under guarantee when he has complied with the warranty conditions in the supply contract

2.3 WHEN THE WARRANTY BECOMES VOID

Besides the cases specified in the supply agreement, the guarantee shall in any case become void:

1. When the implement has been used beyond the specified power limit like (Tractor Horse Power)
2. When repairs made by the customer without authorization from the manufacturer or owing to installation of spurious spare parts, the machine is subjected to variations and the damage can be ascribed to these variations.
3. When the user has failed to comply with the instructions in this handbook.
4. No warranty will be given if the service and greasing is not done on time.

2.4 WARNING

1. Thoroughly read the instruction manual before proceeding with the various operations.
2. Maintain the sub soiler as per the instruction of this hand book to be entitled for warranty.

3. USAGE INSTRUCTIONS

3.1. OVERALL CHECK-UP

Before mounting of Sub-Soiler to tractor make sure that all nuts and bolts are properly secured.

3.2. ATTACHING THE SUB-SOILER TO THE TRACTOR

- Place the sub-soiler duly levelled on the flat piece of land.
- Reverse the tractor to the sub-soiler (Do not drag the sub-soiler)
- Attach the left arm of the tractor to the sub-soiler first.
- Attach the lower right arm, turn the screw until the mounting pin is at the same level as the hole on the tractor arm. If the gap between hole and mounting pin is too close or too distant, turn the control arm in or pull it away to an appropriate distance. You may have to adjust both height and distance at the same time. When the hole at tractor arm and mounting pin are even, insert the pin in the hole and lock it with the lynch pin.

- Attach the central arm to the sub-soiler. To attach, turn the screws on both sides to an equal length. If the arm is too short or too long, turn the screw to adjust both at the same time until aligned with the hole on the central arm.
- After attaching the sub-soiler lift it and adjust the control arm parallel to the ground. When you look from both rear or sideways, the shanks should all be touching the ground uniformly.

3.3 SAFETY INSTRUCTION

DANGER

Understanding the machine safety labels



Safety-Alert Symbol

The machine safety labels shown in this section are placed in important areas on your machine to draw attention to potential safety hazards

On your machine the words DANGER, WARNING, and CAUTION are used with this safety-alert symbol. DANGER identifies the most serious hazards.

The operator's manual also explains any potential safety hazards whenever necessary.



In order to protect yourself always wear adequate clothes and shoes during the operations.



Never allow riders on the tractor or implement unless an additional seat is available.



Be careful when moving around steep gradient to avoid sharp turn.



Never transport the implement on rough roads during the night. When operating, avoid sharp turns that may cause tractor colliding with the implement.

4. TRACTOR PREPARATION AND WORKING

4.1 INSTRUCTION FOR TRACTOR PREPARATION

The following are typical instructions for preparing a tractor for operation:

- The horsepower of tractor selected should match the implement.
- All sub-soiler adjustment should be carried out.
- Select draft and position control setting according to tractor operators manual.

4.2 LEVELING THE SUB-SOILER

The level of the sub-soiler is controlled by the tractor top link. Lateral levelling is controlled by adjusting the length of the tractor right lower link. These adjustments must be made with the sub-soiler prior to operation

4.3 ADJUSTMENT FOR DEEPER PENETRATION

The depth of the penetration can be obtained by the position and draft control levers of the tractor hydraulic system. Higher the tractor power more is the depth of operation. However more depth can be obtained by lowering the shanks.



Fig 2- Soil fracturing pattern

4.4 WARNING FOR DRIVER

- Operate the tractor in low first gear.
- Lift the sub-soiler completely on every turn.
- Never reverse the tractor when the sub-soiler is engaged in the soil.
- Properly mount the three point linkage as mentioned above & lock with lynch pin.
- If sub-soiler stuck with tree roots and stones, stop tractor and lift the sub soiler.
- Keep proper distance from sub-soiler when it is in working.
- Lift the sub-soiler completely during transport.

4.5 TROUBLING SHOOTING

The "FIELDKING USA" sub soiler uses a vertical shank to break- up Hardpan, trench or aerate the soil. it is a simple and reliable system that requires minimal maintenance. In the following section, we have listed many of the problems, causes & solutions to the problems that you may encounter. If you encounter a problem that is difficult to solve, even after having read through this trouble shooting section, Please call your local FIELDKING USA Dealer. Before you call, please have this operator's manual & the serial number from your sub soiler ready.

PROBLEM	CAUSE	SOLVE
Blade won't penetrate soil	Hard ground condition	<ol style="list-style-type: none"> 1. Replace shovel if badly worn. 2. Be sure 3 point hitch is set in "float" or "draft" Mode. 3. Set Shank angle 4. Add weight to frame
High power required.	<ol style="list-style-type: none"> 1. Wrong Shank Angle 2. Shovel worn 	<ol style="list-style-type: none"> 1. Reset Shank Angle. 2. Replace shovel.
Shank not taking depth /not working	Shear bolt broken	Change shear bolt

5. MAINTENANCE

5.1 MAINTENANCE INSTRUCTIONS

If sub-soiler is working on stony land then maintenance goes up. Please follow these rules to get the best results:

- If sub-soiler is new then tightened all nuts and bolts after few trials runs.
- Constantly check for tightness of nuts and bolts.
- When the length of the points is reduced by 1 inch, reverse it and use the other side of the points, when both side of the strip are worn out replace it with the new one.

5.2 STORAGE OF MACHINE AFTER WORK

- Wash the sub-soiler completely after work.
- Replace the worn out nuts and bolts.
- If sub-soiler has to remain unused for long time then clean it & apply a layer of un-used oil/grease for rust prevention.

These steps will enhance the life of your sub-soiler

6. PART CATALOGUE OF 1 & 3 ARM SUB-SOILER

SL. NO.	PART NAME	PART NO.	QTY.
1	FRAME ASSEMBLY	76150001	1
2	STAND PIPE ASSY.	76160001	2
3	TYNE ASSY.	76170001	1
4	HEX HEAD BOLT M24X130X3P	10260416	1
5	HEX HEAD BOLT M18X120X2.5P	10260337	1
6	NYLOCK NUT M24X3P	10280075	1
7	NYLOCK NUT M18X2.5P	10280020	1
8	WIRELOCK PIN DIA 9.5X76L	10020113	2
9	LINCH PIN 10MM	10020022	3
10	PIN 28X125MM	10020095	2
11	PIN 25X120MM	10020035	1

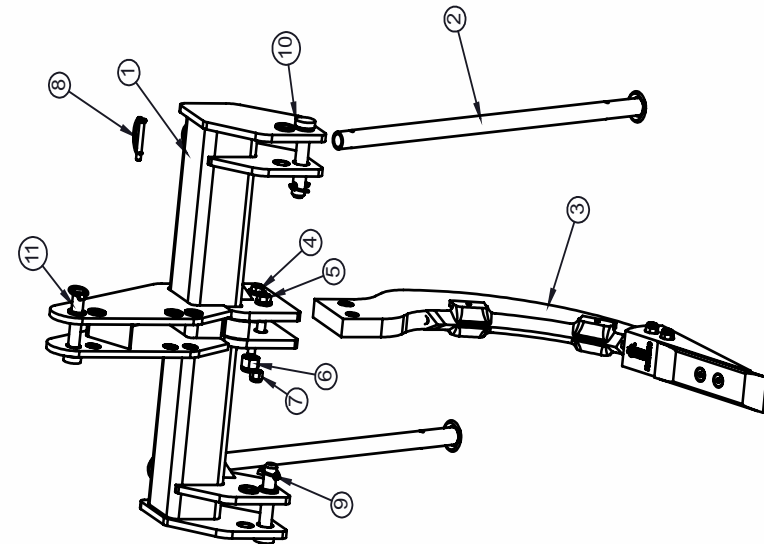

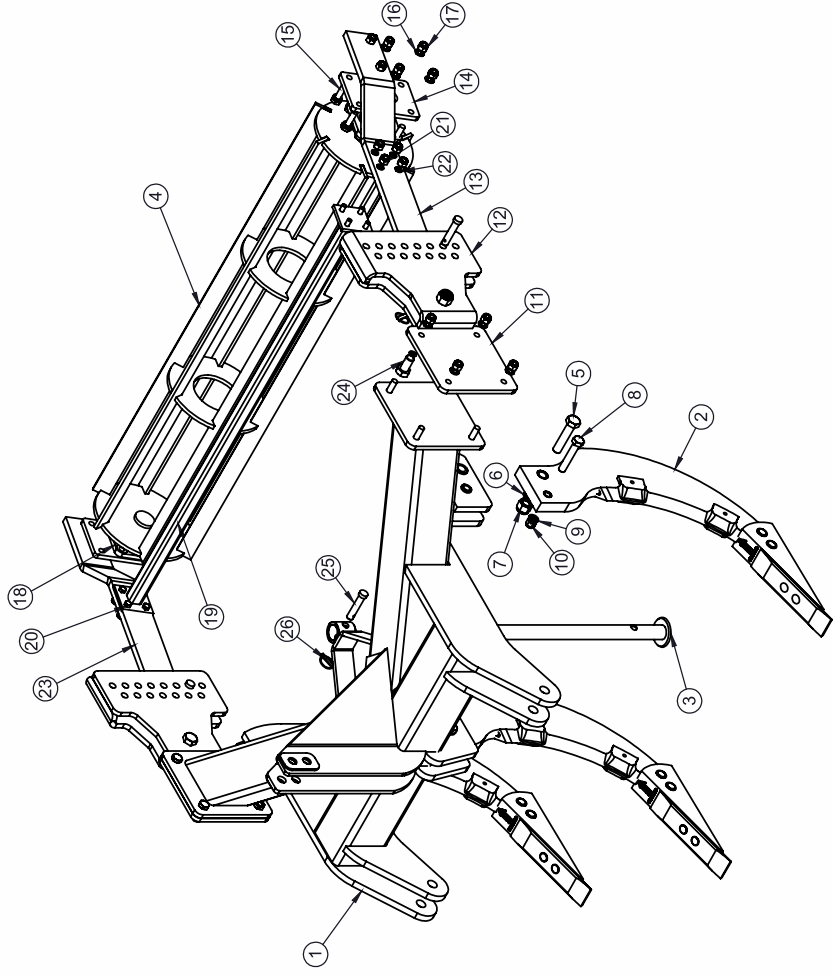

HEAVY DUTY SUBSOILER WITH CRUMBLER 2 & 3 BOTTOM PARTS LIST.

SL. NO.	PART NAME	PART NO.		QTY.
		97010024	97010018	
1	FRAME ASSEMBLY	79250001	78120001	1
2	TYNE ASSEMBLY	76170001		2
3	STAND PIPE ASSEMBLY	78120002		1
4	CRUMBLER ASSEMBLY	78140014	78140012	1
5	HEX HEAD BOLT M24X130X3P	10260416		2
6	SPRING WASHER 24MM	10280075		4
7	NYLOCK NUT M24X3MM	10270027		4
8	HEX HEAD BOLT M18X120X2.5P	10260337		2
9	SPRING WASHER 18MM	10270006		2
10	NYLOCK NUT M18X2.5MM	10280020		2
11	SIDE ADJUSTING PLATE BIG	78120014		2
12	SIDE ADJUSTING PLATE SMALL	78120015		2
13	CRUMBLER MOUNTING FLAT RHS	78140010		1
14	CRUMBLER MOUNTING PLATE	78140002		2
15	HEX HEAD BOLT M16X55X2MM	10260454		20
16	SPRING WASHER 16MM	10270005		20
17	NYLOCK NUT M16X2MM	10280005		20
18	UC BEARING F210	10050031		2
19	SUPPORT PIPE ASSEMBLY	76410004	78140013	1
20	HEX HEAD BOLT M12X50X1.75P	10260363		8
21	NYLOCK NUT M12X1.75P	10280025		8
22	SPRING WASHER 12MM	10270003		8
23	CRUMBLER MOUNTING FLAT LHS	78140011		1
24	HEX HEAD BOLT M24X90X3P	10260469		2
25	PIN 19X90MM	10020026		3
26	LINCH PIN 8MM	10020045		3

TYNE ASSEMBLY

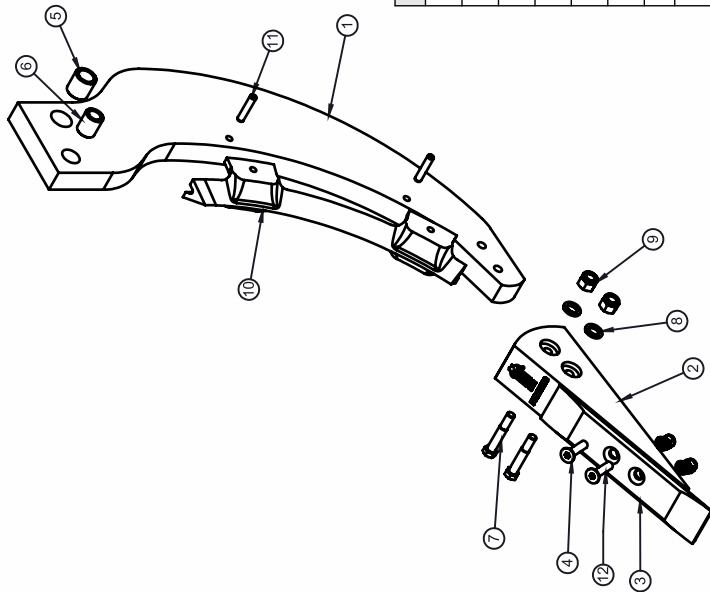

SL. NO.	PART NAME	PART NO.	QTY.
1	TYNE	76170002	1
2	RIPPER SHOE	10320009	1
3	SUBSOILER SHOVEL	75200002	1
4	CSK BOLT M12X65X1.75P	10260516	1
5	TYNE BIG BUSH	76170006	1
6	TYNE SMALL BUSH	76170005	1
7	HEX HEADBOLT M12X80X1.75P	10260447	2
8	SPRING WASHER 12MM	10270003	2
9	NYLOCK NUT M12X1.75MM	10280025	2
10	TYNE EDGE	76170007	1
11	SPRING DOWEL PIN 10 x 65	10210028	2
12	CSK BOLT M12X50X1.75P	10260050	1

DELIVERY CHECKLIST

Dealer Pre-Delivery (Please Tick)

1. Dealer Pre-Delivery Checklist

1. The customer or person responsible has been given the operator's manual.
2. The customer undertakes to read the complete operator's manual and understands all aspects of the manual before operation of the machine.
3. All safety, operational and maintenance information have been explained and demonstrated.
4. All greasing and oil points, stickers, guarding and ID plate have been identified and physically pointed out.
5. The customer agrees that it is his responsibility to read and carry out the safety, maintenance and operation as per this operator's manual.

Customer Delivery (Please Tick)

2. Customer Delivery Checklist

1. The customer or person responsible has been given the operator's manual.
2. The customer undertakes to read the complete operator's manual and understands all aspects of the manual before operation of the machine.
3. All safety, operational and maintenance information have been explained and demonstrated.
4. All greasing and oil points, stickers, guarding and ID plate have been identified and physically pointed out.
5. The customer agrees that it is his responsibility to read and carry out the safety, maintenance and operation as per this operator's manual.

Please Complete all Dealer information Below

Dealer Information

Dealer's Name.....

Address.....

State..... Postcode.....

Phone..... Fax.....

Email.....

Service Person.....

I confirm that the pre-delivery service was performed on this machine.

Signature.....

Date.....

Comments.....

Please Complete all Customer Information Below

Customer Information

Customer's Name.....

Address.....

State..... Postcode.....

Phone..... Fax.....

Email.....

Delivery Person.....

I confirm that all of the delivery checks were explained and performed.

Signature.....

Delivery Date.....

Comments.....



WARRANTY CARD
Customer Copy

CUSTOMER NAME Mr./ Mrs :

ADDRESS :

MOBILE NO. :

Email :

NAME OF IMPLEMENT :

MODEL NO. :

YEAR OF Mfg. :

SERIAL NO. :

REGISTRATION NO. :

DATE OF PURCHASING :

NAME OF DEALER :

Customer`s Signature

Dealer`s Signature

FIELDKING USA, INC.

960 Holmdel Road Suite 2-02, Holmdel, NJ 07733, USA

✉ usa@fieldking.com, 🌐 www.fieldkingusa.com

WARRANTY CARD
Company Copy

CUSTOMER NAME Mr./ Mrs :

ADDRESS :

MOBILE NO. :

Email :

NAME OF IMPLEMENT :

MODEL NO. :

YEAR OF Mfg. :

SERIAL NO. :

REGISTRATION NO. :

DATE OF PURCHASING :

NAME OF DEALER :

Customer's Signature

Dealer's Signature

FIELDKING USA, INC.

960 Holmdel Road Suite 2-02, Holmdel, NJ 07733, USA

✉ usa@fieldking.com, 🌐 www.fieldkingusa.com

WARRANTY CARD
Dealer Copy

CUSTOMER NAME Mr./ Mrs :

ADDRESS :

MOBILE NO. :

Email :

NAME OF IMPLEMENT :

MODEL NO. :

YEAR OF Mfg. :

SERIAL NO. :

REGISTRATION NO. :

DATE OF PURCHASING :

NAME OF DEALER :

Customer's Signature

Dealer's Signature

FIELDKING USA, INC.

960 Holmdel Road Suite 2-02, Holmdel, NJ 07733, USA

✉ usa@fieldking.com, www.fieldkingusa.com