







-  Tillage
-  Haulage
-  Landscaping
-  Seeding & Plantation
-  Crop Protection
-  Harvest
-  Post Harvest

Solutions...



17-09-2019

FIELDKING
USA

Flip Plow



FIELDKING USA, INC.

960 Holmdel Road Suite 2-02, Holmdel, NJ 07733, USA

✉ usa@fieldking.com, www.fieldkingusa.com

➤ [Operator Manual](#) ➤ [Service Manual](#) ➤ [Part Catalogue](#)

CONGRATULATIONS!

You have invested in one of the best implements of its type in the market today.

The care you give your "FIELDKING USA" implement will greatly determine your satisfaction with its performance and its service life. A careful study of this manual will give you a thorough understanding of your new implement before operating.

If your manual is lost or destroyed, "FIELDKING USA" will be glad to provide you a new copy. Visit to nearest dealership & get a copy. Most of our manuals can also be downloaded from our website at www.fieldkingusa.com.

As an authorized "FIELDKING USA" dealer, we stock genuine "FIELDKING USA" parts which are manufactured with the same precision and skill as our original equipment. Our trained service persons are well informed on methods required to service "FIELDKING USA" equipments and are ready to help you.

Should you require additional information or assistance, please contact us.

YOUR AUTHORIZED

FIELDKING USA DEALER

BECAUSE "FIELDKING USA" MAINTAINS AN ONGOING PROGRAMME OF PRODUCT IMPROVEMENT, WE RESERVE THE RIGHT TO MAKE IMPROVEMENTS IN DESIGN OR CHANGE IN SPECIFICATION WITHOUT INCURRING ANY OBLIGATION TO INSTALL THEM ON UNITS PREVIOUSLY SOLD. BECAUSE OF THE POSSIBILITY THAT SOME PHOTOGRAPHS IN THIS MANUAL WERE TAKEN OF PROTOTYPE MODELS, PRODUCTION MODELS MAY VARY IN SOME DETAIL. IN ADDITION, SOME PHOTOGRAPHS MAY SHOW SHIELDS REMOVED FOR THE PURPOSE OF CLARITY. NEVER OPERATE THIS IMPLEMENT WITHOUT ALL SHIELDS IN PLACE.

TO THE PURCHASER

This manual contains valuable information about your new "FIELDKING USA" Flip Plow. It has been carefully prepared to give you helpful suggestions for operating, adjusting, servicing and ordering spare parts.

Keep this manual in a convenient place for quick and easy reference. Study it carefully. You have purchased a dependable and sturdy Flip Plow but only by proper care and operation you can expect to receive the service and long life designed and built into it.

Sometime in the future your Flip Plow may need new parts to replace which are worn out or broken. If so, go to your dealer and provide him equipment's detail like model and part number.

CUSTOMER INFORMATION

Name _____

Purchased From _____

Date of Purchase _____

Model No. _____

Serial No. _____

PURCHASER / OPERATOR'S RESPONSIBILITY

1. Read and understand the information contained in this manual.
2. Operate, lubricate, assemble and maintain the equipment in accordance with all instructions and safety procedures in this manual.
3. Inspect the equipment and replace or repair any parts that are damaged or worn out which under continued operation would cause damage, wear to other parts, or cause a safety hazard.
4. Return the equipment or parts to the authorized "FIELDKING USA" dealer, from where it was purchased, for service or replacement of defective parts that are covered by warranty. (The "FIELDKING USA" Factory may inspect equipment or parts before warranty claims are honored.)
5. All costs incurred by the dealer for traveling to or transporting the equipment for warranty inspection and claims will be borne by the customer.

- 1. Introduction**
- 2. Safety Instructions**
 - a Safety While Attaching & Detaching
 - b Safety While Connecting Hydraulic Lines
 - c Safety While Operating the Machine
 - d Safety for Maintenance
 - e Safety on Highway Transport
- 3. Warning Stickers**
- 4. Preparation of the Tractor**
 - a Tyres
 - b Lift Rods
 - c Top Link
 - d Chains and Sway Blocks
 - e Hydraulics
 - f Hydraulic Equipment
- 5. Use**
 - a General Instructions
 - b Top Link Connection
 - c Adjustment of the Outer Turnbuckle
 - d Length of Top Link
 - e Clearance for the turnover operation
 - f On the field
 - g 3 point attachment
 - h Height adjustment of the drawbar
- 6. Attaching and Detaching the Plough**
- 7. Turning the Plough Frame**
- 8. Adjustments**
 - a Front furrow width
 - b Angle adjustment
 - e Working depth
- 9. Overload Safety Devices**
- 10. Maintenance**
- 11. Troubleshooting**
 - a Penetration, Depth guidance & Slippage
 - b Others
- 12. Part Manual**

1. INTRODUCTION

Read carefully this manual

- This handbook contains operating and maintenance instructions plus a list of the parts supplied as spares for the implement.
- This manual should be considered as a part of the equipment and should follow it whenever it is sold.
- The FIELDKING USA implement have been designed purely for agricultural use. Any use beyond the one stipulated above, will not be considered.
- All information, pictures, specifications in this manual are based on the newer information available at the time of publication. Pictures and drawings might not represent standard equipment and show optional attachments.
- The manufacturer reserves the right to make any change at any time without any obligation to notice or to modify any delivered or already sold machine.
- The FIELDKING USA implement should only be operated, maintained and repaired by such persons who have been made acquainted with it & who have been advised about the dangers. If the machine has been modified in any way from the original design without written agreement from FIELDKING USA, the manufacturer does not accept any liability or injury or warranty. Warranty would become void.
- The applicable accident prevention advices as well as the generally accepted safety, technical, working, medical and road traffic rules should be adhered to.
- So please, when you see it in this manual or on the equipment, strictly follow the given information.



- This symbol is used in the following manual to catch your attention on warnings concerning your safety.

2. SAFETY INSTRUCTIONS

2.1 Safety while attaching and detaching

- Do not let anyone to stand between the machine and the tractor when you back up to hitch.
- Before leaving the tractor to hitch or unhitch, set tractor parking brakes.
- Before mounting or dismounting implements on / from the three-point linkage, move the raise-lower control to the position at which accidental rising or lowering cannot take place. Completely lower the machine to the ground before unhitching. Make sure it is on a level and firm surface.
- In the case of three-point linkage mounting, ensure that the tractor balls and the mounting pins of the implement are of the same category.
- Never attempt to attach the machine if the pins, tractor hitching balls, tractor draw bar or machine linkage are worn, cracked or not compatible.
- Remove pressure from hydraulic lines before disconnecting them.

- When driving on roads with the implement raised, the raise-lower control must be locked to prevent accidental lowering.
- Before leaving the machine for storage, make sure it is a safe place and that there is no risk to damage whether anything or anyone.

2.2 Safety while connecting hydraulic lines

- The hydraulic circuit is highly pressurised.
- Never use your hands to locate a hydraulic leak. Hydraulic fluids escaping under pressure have sufficient force to penetrate the skin, causing severe injury. In case of any injury, see a doctor immediately.
- When connecting hydraulic rams, the pipes must be connected as directed.
- Before connecting hydraulic circuit, make sure that there is no pressure on both sides, (tractor and machine).
- Regularly check hydraulic lines and connections. Replace any damaged or leaking component by an original part with the same specifications. The replacement pipes must comply with the technical specification laid down by FIELDKING USA.
- Before any operation on the hydraulic equipment, lower the machine to the ground and release the hydraulic pressure where possible and switch off the tractor engine.

2.3 Safety while operating the machine

- The operator should familiarize himself / herself with all controls and their functions before starting work.
- Do not attempt to do any adjustment if you have not perfectly understood its procedure.
- Always use tools or equipments appropriate to the job you are doing. All related tools are provided along with the implement.
- Learn how to operate your machine and how to use its controls. Do not let anyone operate without instruction.
- Do not allow anyone to stand close to the machine.
- Do not allow anyone to stand close to pivot points. On all pivoting parts actuated by power assistance (e.g. hydraulics), there exists danger of injury by bruising and crushing.
- Never attempt any operation on machine while it is in motion.
- Wear close fitting clothing and appropriate safety devices for the job you have to do (heavy leather gloves, safety shoes, earplugs, etc.).
- Do not extend turnbuckle adjusters too much to avoid any threads damaging or ultimately pulling out.
- Only one person (the operator) should be in tractor's cab when it is operation. No one on the machine while working or while traveling on the road.

- If any unusual vibration is heard or felt, stop the machine. Find the problem and solve it before starting operation again.
- If your machine is equipped with a hydraulic folding mechanism, always use it from tractor's cab, once you are sure that folding area is free from spectators or obstacles.

2.4 Safety for Maintenance

- Maintenance area should be clean, dry, with enough light and ventilation.
- Repair, maintenance and cleaning operations as well as adjustments and remedy of function faults should principally be conducted with engine stopped and brakes applied with the engine key removed.
- For any operation on the machine on raised position, always securely support all components before starting maintenance.
- For replacing any parts with cutting edges, always use suitable tools and gloves.
- Maintenance operations on elements under pressure or under tension require specific procedures and equipments. Only qualified persons shall perform them in appropriate conditions.
- After servicing, remove all tools, components and parts that were used.
- Regularly check the tightness of wheel studs, wearing parts' bolts and all other bolts and nuts.
- Always use genuine parts corresponding to the manufacturer's technical & specification requirements.

2.5 Safety on Highway Transport.

FOR YOUR OWN SAFETY AND THE ONE OF THE OTHER, RESPECT THE FOLLOWING RULES.

All FIELDKING USA equipments shall be used, complying with the area's current rules and laws concerning safety instructions, accident prevention and provision of Highway Code.

- Before road transport, always check for wheel studs and wheel mounting brackets, carriage bolt tightness, general tyre state and pressure. Do not drive with low pressure, cuts or damaged tyres or rims.
- As well as the notes in these instructions, the operator is advised to comply with the generally applicable safety at work regulations and those relating to use of the public highway.
- When driving on public roads with a raised machine, the lifting control lever should be locked against unintentional lowering.
- Use all devices required by your area's current laws (lights, reflectors, signs). They might be removed during field operations to prevent any sort of damage. It is the operator's responsibility to comply with current laws and to follow the regulations.
- Handling behaviour, steer-ability and braking are influenced by mounted implements, trailers and ballast weights. Check for sufficient steer ability and braking.

- Regularly check hitching pins, change them if necessary. Tractor's ball joint may also wear, do not hesitate to replace them with new ones as per the manufacturer's standards.
- Drive at reasonable speed complying with local laws to always keep control of tractor and equipment. Pay special attention on irregular or rough roads
- Tractor used for road transport shall have the same power rating and weight as the one used for field operations.
- Never attempt any manoeuvre if the area is not free from spectators.
- If your machine is equipped with a folding mechanism (manual or hydraulic), use it making sure folding area is free from spectators and obstacles.
- Follow all safe driving practices when travelling, especially on corners, rough or narrow roads.
- Before leaving the tractor, lower the machine to the ground. Apply the parking brake, stop the engine and remove the ignition key.
- Do not allow anybody between the tractor and the implement if the parking brakes are not applied.

3. WARNING STICKERS

3a. General Instructions

The FIELDKING USA implement is equipped with all features to ensure safe operation. Where potential danger areas of the implement cannot be fully safeguarded, warning stickers are placed which draw attention to these. Damaged, lost or unreadable warning stickers must be replaced immediately.

3b. Meaning of the Stickers

Familiarise with the meaning of the stickers. The following descriptions inform about them in detail.

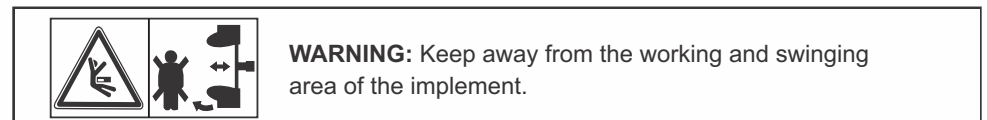
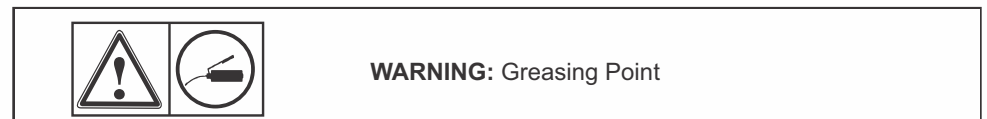
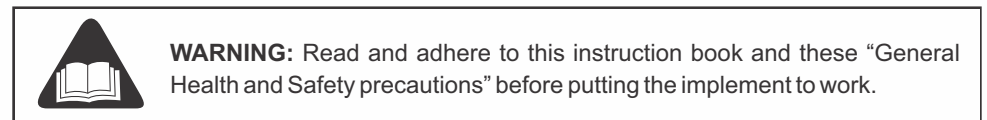



WARNING: Keep away from the turning and swinging area of the implement.



DO NOT STAND NEAR THE MACHINE WHILE IT IS WORKING

This symbol expresses not to stand near the machine while it is working to avoid any injury.



WARNING: Hydraulic accumulator contains gas and oil under pressure. For removal and repair, instructions in technical manual must be followed.

4. PREPARATION OF THE TRACTOR

4a. Tyres

The Pressure – especially in the rear tractor tyres – must be equal. In heavy conditions it may be necessary to add wheel weights and / or water ballast. (See manufacturer’s instructions).

4b. Lift Rods

Adjust lift rods to equal length. (See manufacturer’s instructions).

4c. Top Link

Where there are alternative fitting positions at the tractor for the top link, fit the tractor-sided top link as high as possible.

4d. Check Chains or Sway Blocks of the Three Point Linkage

Chains or sway blocks MUST be adjusted so that the lower link is always free to move sideways during ploughing.

Attention! Some tractors are equipped with automatic “check devices” which require special adjustments. If a tractor suddenly shows side draft or if the L/H and R/H front width of the plough is different, an unlocked “check device” could be the reason for that. In such a case the function of the automatic “check device” must be checked. (See manufacturer’s instructions)

4e. Hydraulics

For working, the tractor hydraulics must be set a ‘Draft’ or ‘Mixed’ Control. See manufacturer’s instructions.

4f. Required Hydraulic Equipment

The hydraulic equipment used in this plough is a double acting cylinder.

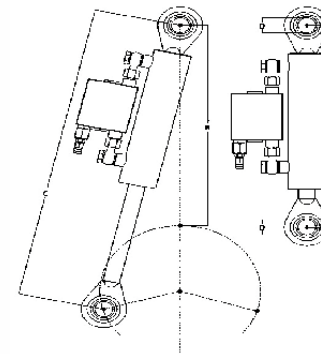

- The picture shows the location of the pressure control valve of the cylinder.
- The adjustment of the allen screw will increase / decrease the pressure as per requirement.

5. USE

5a. General Instructions

Before the first use, it is recommended – with fully lowered implement – to carry out the following adjustments at the farm. Afterwards only few adjustment corrections have to be carried out in the field.

5b. Top Link Connection

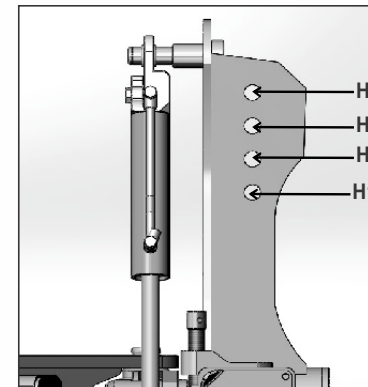

Connect top link to headstock (A) and ensure that the top link rises slightly towards the plough. There are 4 holes provided in the headstock (A) for different type of tyre conditions of the tractor. The relation of the tractor tyre to the mounting hole can be summarized from the following table.

TRACTOR TYRE TYPE	MOUNTING HOLE
14.9 – 26 / 28 / 30	1
16.9 – 26 / 28 / 30	2
18.4 – 26 / 28 / 30	3
23.1 – 26 / 28 / 30	4

5c. Adjustment of the outer Turnbuckle of the Adjustment Centre Optiquick

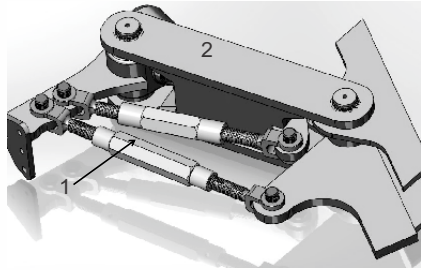

The outer turnbuckle (1) has been adjusted to the extreme to allow compact transport on lorries. Adjust this turnbuckle to a length similar to that of the main link (2). Final adjustments can take place in the field.

5d. Length of the Top Link

Lower plough and adjust length of top link, so that the first body is approx. 0.4" to 1.1" higher than the rear one.

When the top link is fitted to the mounting hole, it must be adjusted with lowered plough until the top link pin is unloaded but is still positioned in front of the mounting hole and plough is also 10 to 30 mm higher in front than in the rear.

5e. Clearance for the Turnover Operation

Raise the plough fully and then turn the plough carefully.

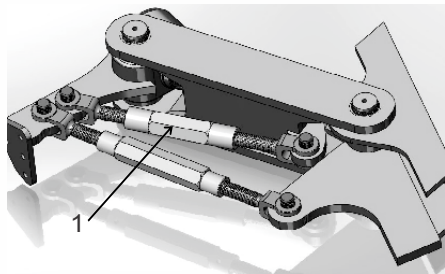

Check whether there is sufficient clearance between plough / depth wheel and ground. If not, lengthen the inner turnbuckle (1), set drawbar deeper, fit top link to a higher hole in the headstock or use any hydraulic frame swing-in assy.

5f. On the field

Set tractor hydraulics to "Draft Control" or "Mixed Control".

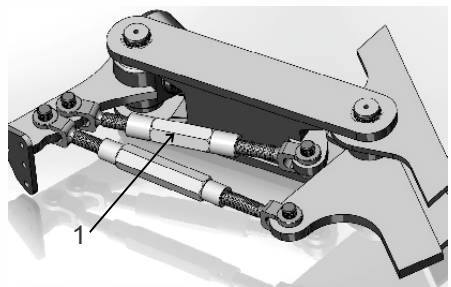

Set in the plough & adjust the length of the top link, vertical pitch, front furrow width, working depth as required.

Attention: The tractor hydraulics must be adjusted so that the top link is always under tension, especially with ploughs of 5 or more furrows. Due to that the weight will be transferred to the tractor resulting in less slippage and reduced fuel consumption. Adjust the tractor plough line by means of inner turn buckle (1). This will eliminate side draft & optimise the pull point which again will reduce slippage & fuel consumption.

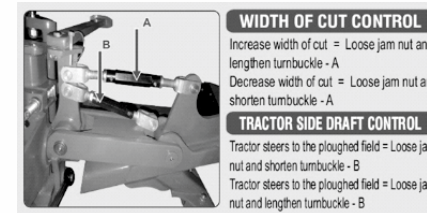

WIDTH OF CUT CONTROL

Increase width of cut = Loose jam nut and lengthen turnbuckle - A
Decrease width of cut = Loose jam nut and shorten turnbuckle - A

TRACTOR SIDE DRAFT CONTROL

Tractor steers to the ploughed field = Loose jam nut and shorten turnbuckle - B
Tractor steers to the ploughed field = Loose jam nut and lengthen turnbuckle - B

Kindly follow the instructions as per requirements and field conditions.

5g. Three Point Attachment

The category of the three point linkage must be the same with the implement as well as with the tractor. If there is no correspondence, either the point linkage of the tractor must be adapted or the drawbar (1) and if required the top link pin must be replaced by a corresponding version.

5h. Height Adjustment of the Drawbar

Type-1

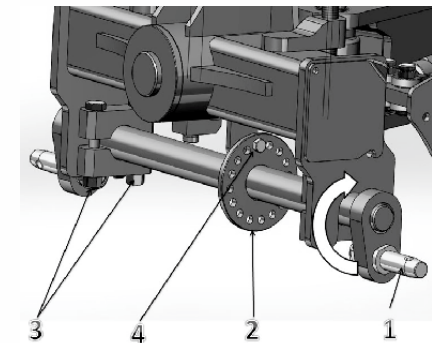

The drawbar (1) can be set in different height positions corresponding to the hole alignment in the drawbar height adjustment disc (2).

Fundamentally the top position should be chosen to reach a better entry of the implement. The lower position should be chosen, only when the implement cannot be lifted sufficiently for the turning procedure.

The cutting depth of the plough can be modified and set manually as per requirements. These requirements depend upon:-

- Soil condition, Tractor HP, Tractor tyre type, mounting position of the top link.

If it is required to change the position of the drawbar, the clamp tightening bolts (3) should be loosened and the adjustment disc bolt (4) should be removed. The drawbar then can be rotated at its position thus increasing / decreasing the height of the lower linkage pins. At a suitable height, the adjustment disc bolt (4) should be relocated and the nut tightened. Further, the clamp tightening bolts (3) should be tightened back to secure the drawbar.

Type-2

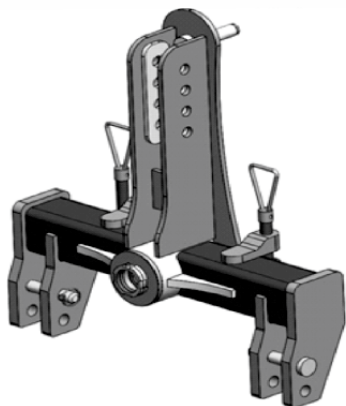

As seen in the pic, there is no drawbar, but the lower links can be attached to the pins provided and the top link at one of the 4 holes depending on the conditions.

2 different holes are provided at different height locations for attaching the lower link of the tractor.

6. ATTACHING AND DETACHING THE PLOUGH

6a. Attaching

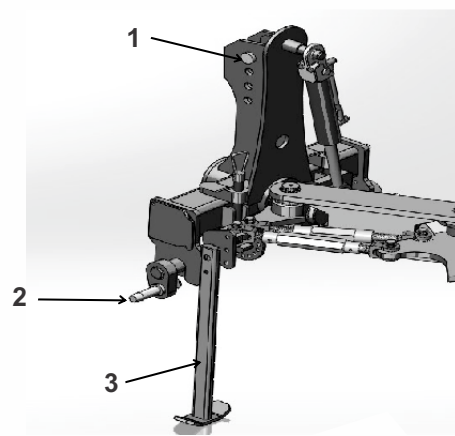

Attach the plough parked in working position to the tractor as follows:

- Set tractor hydraulic to 'Position Control'.
- Attach lower links to the drawbar (2) and secure.
- Pull up stand (3) and secure.
- Fit top link to headstock so that it rises slightly towards the plough during work.
- Secure top link pin (1). Use top link pin delivered with the plough, only.

- Connect hydraulic hoses.
- For work, set tractor hydraulic to 'Draft' or 'Mixed' Control. See also the Operating manual of the tractor manufacturer.
- If the plough is to be transported on public roads, fit SMV hologram boards respectively lighting equipment.

Attention:

6b. Detaching

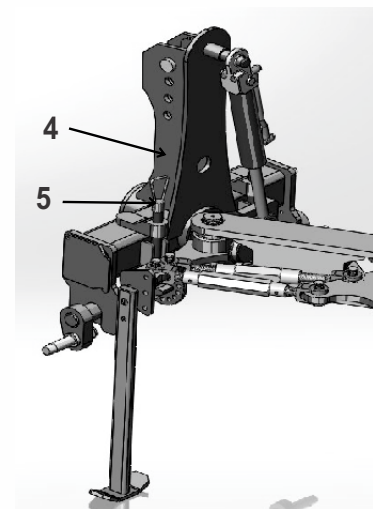

- Park the plough on a firm and level ground.
- Turn plough to working position.
- Set tractor hydraulic to "Position Control".
- Lower plough completely.
- Stop tractor engine and move both spool valve levers to release pressure.
- Remove top link from headstock.
- Remove hydraulic hoses and fit protective caps.
- Put hydraulic hoses with their couplings between headstock (4) and adjuster nut (5).
- Unsecure and swing down stand (3).
- Remove lower links from the drawbar.

Attention - When the plough is parked the headstock (4) is in oblique position, which can make a later re-attachment difficult. So before parking the plough the headstock (4) should be "set straight" by means of corresponding adjustment of the adjuster nut (5). This eases the later attachment. Before the next use, the headstock to original position again by means of turning back the adjuster nut by the same amount.

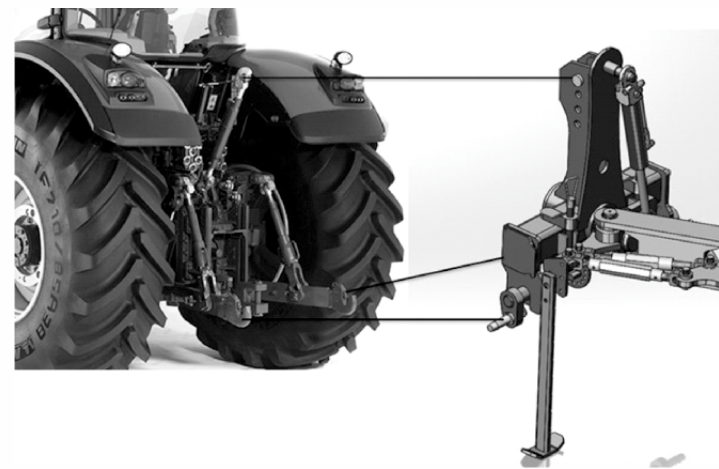

Note - The figure shows the positioning of the three point linkage and the locking positions of the reversible mould board plough to the tractor.

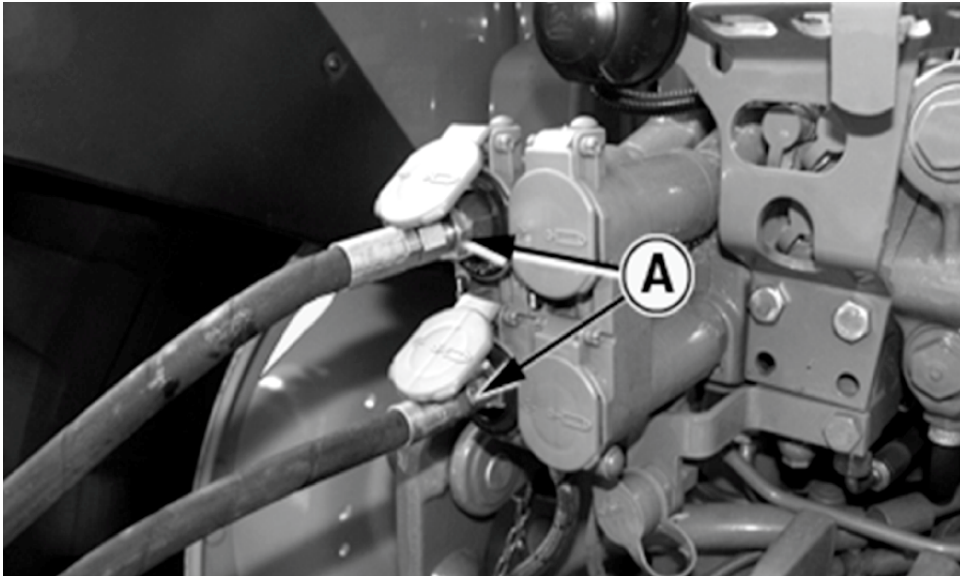

Note: - The figure shows the attachment location (A) of the QRC (Quick Release Coupling) of the hose pipe.



Read and adhere to the General Safety Instructions as well as to the Instructions 'Attached Implements'.

7. TURNING THE PLOUGH FRAME

General Instructions

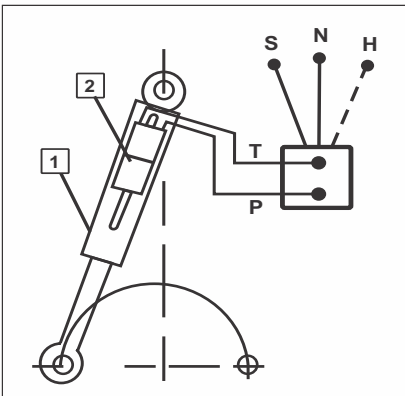

The turnover device is equipped with a double acting turnover ram (1) with automatic turnover valve and automatic acting lock valve for the connection to a double acting spool valve. In combination with a separate return pipe to the oil tank of the tractor it is possible to connect the turnover ram to a single acting tractor spool valve.



Read and adhere to the General Safety Instruction as well as to the instructions 'Hydraulic Equipment'.

- Before each turnover procedure, it must be ensured that no persons are standing in the turning and swinging area of the plough.
- Operate turnover device from the tractor seat, only.
- Do not bend hydraulic hoses.
- Keep the hose connections clean.

8. ADJUSTMENTS

- Read and adhere to the General Safety Instructions.
- The implement may only be operated, maintained and repaired by such persons who have been made acquainted with it and who have been advised about the dangers.
- Adjustments and maintenance operations as well as eliminations of malfunctions should principally be carried through with engine stopped and parking brake applied. Most specifically, tractor ignition key removed.

8a. Front Furrow Width

Adjustment by means of a Turnbuckle

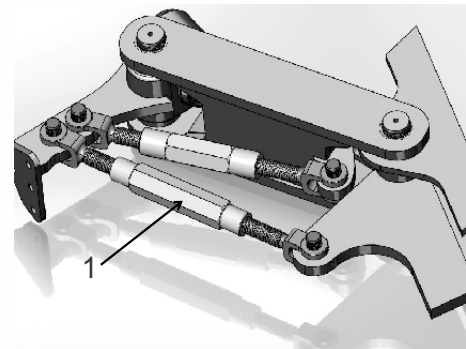

The implement is already set and provided to give the maximum efficiency in the standard working width and depth.

In case, width of cut needs to be modified, adjust outer turnbuckle (1) to make the front furrow width equal in width to the other bodies.

Front furrow too narrow => lengthen outer turnbuckle (1)
 Front furrow too wide => shorten outer turnbuckle (1)

8b. Angle Adjustment

General Instructions

With the plough in work at the required depth, the legs should be approximately vertical. If not, the angle must be adjusted as follows:

Angle Adjustment (with double acting turnover ram)

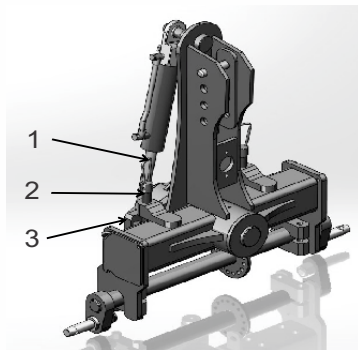

- Lift the plough 3 inch – 4 inch.
- Momentarily pressurize port 'P' of the turnover ram (1). Then the arm (2) Turns away from its stop.
- Adjust I-bolt (3) as required.
- Set tractor spool valve into the opposite position to return plough and arm (2) to its stop.

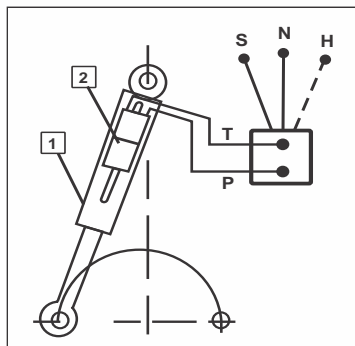

- Lower the plough.
- Check that plough legs are vertical after ploughing a few meters, readjust if necessary.

8c. Working Depth

The working depth adjustment occurs via the tractor hydraulics. The instructions for the adjustment of the tractor hydraulics can be learned from the operating manual of the tractor manufacturer. In each case the tractor hydraulics must be set to 'Draft' or 'Mixed' control.

Type -1

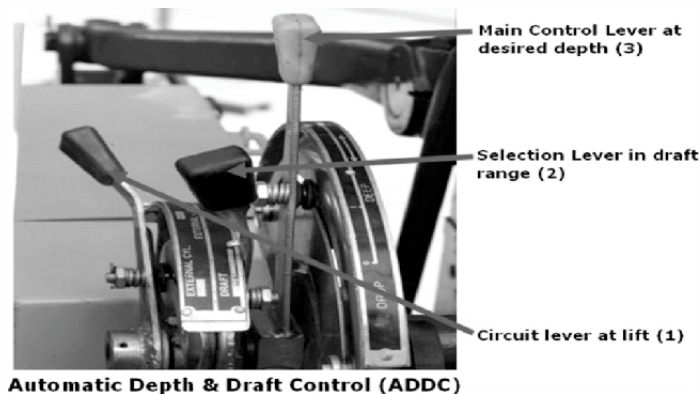

Automatic Depth & Draft Control (ADDC)

Type -2

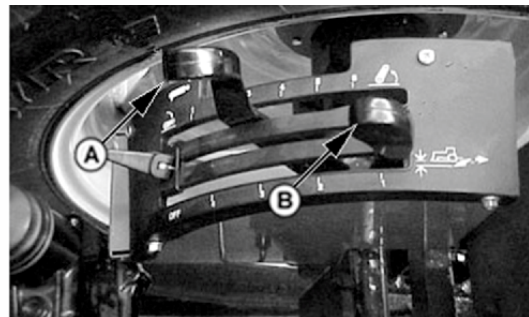

In the above pic :- A = Position control lever B = Draft control lever

9. OVERLOAD SAFETY DEVICES

Shear bolt Device

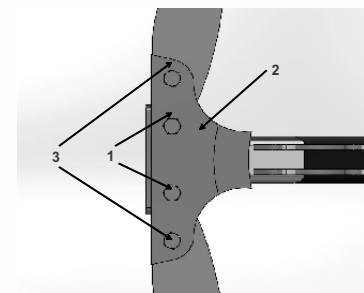

The plough is fitted with shear bolts (Grade 8.8) (1) inside the leg brackets (2) as standard.

After the breakage of the shear bolt (1), swing back the damaged plough body with lifted plough after loosening the pivot bolt (3) and removing the shear bolt sections.

Fit new shear bolt and tighten it together with the pivot bolt (3).

10. MAINTENANCE

All grease points must be greased regularly with environment friendly grease according to the following table. For a long operation break, the piston rods of the hydraulic rams must be greased with non-acid grease. The polished areas of wearing parts and the pins as well as adjusting devices must be treated with grease regularly.

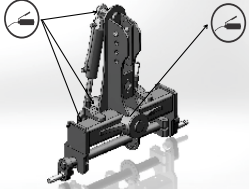
Bearing of turnover device and pivot points		<ul style="list-style-type: none"> •Greasing to be done after every 10 working hours. •Greasing to be done before & after every winter break.
---	---	---

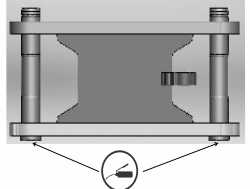
Adjustment Centre		<ul style="list-style-type: none"> •Greasing to be done after every 10 working hours. •Greasing to be done before & after every winter break.
-------------------	---	---

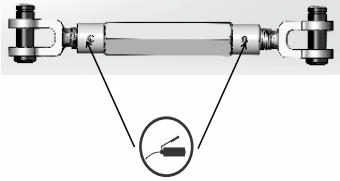
Turnbuckles		<ul style="list-style-type: none"> •Greasing to be done before & after every winter break.
-------------	---	---

Thread of angle adjustment		<ul style="list-style-type: none"> •Greasing to be done before & after every winter break.
----------------------------	--	---

- All bolts and nuts must be checked regularly and tightened if required.
- Porous or defective high pressure hoses must be replaced immediately with genuine FILEDKING USA hoses.
- Worn shares, mouldboard edges, mouldboard, landslides and so on must be replaced on time, so that supporting parts will not be damaged.

 Read and adhere to the General Safety Instructions as well as to the Instructions 'Maintenance'.

11. TROUBLE SHOOTING

11a. Penetration and Depth Guidance of the Plough & Slippage

Malfunction	Reason	Remedy
Plough does not stay in the ground.	<ul style="list-style-type: none"> a) Penetration force is too low. b) Drawbar is fitted too deep. 	<ul style="list-style-type: none"> a) Increase the distance between point and frame (not more than 0.4"-1.1"). b) Fit drawbar to the upper position.
Plough does not penetrate into the ground.	<ul style="list-style-type: none"> a) Penetration angle of the shares is too small. b) Drawbar is fitted too deep. c) Top link is fitted too high at the headstock. 	<ul style="list-style-type: none"> a) Increase the distance between the point and the plough frame (not more than 0.4"-1.1"). b) Fit drawbar to the upper position at the head stock. c) Fit top link in a deeper position.
Tractor shows too much slippage.	<ul style="list-style-type: none"> a) Drawbar is fitted too deep b) Draft control is not adjusted correctly. 	<ul style="list-style-type: none"> a) Fit drawbar to the upper position. b) Adjust draft control again.

11b. Others

Malfunction	Reason	Remedy
Shear bolt of the body shears often.	Incorrect shearbolt is fitted.	Use original shearbolts. Fit the shearbolts from the furrow side of the plough.

12. Part Catalogue

FLIP LOW

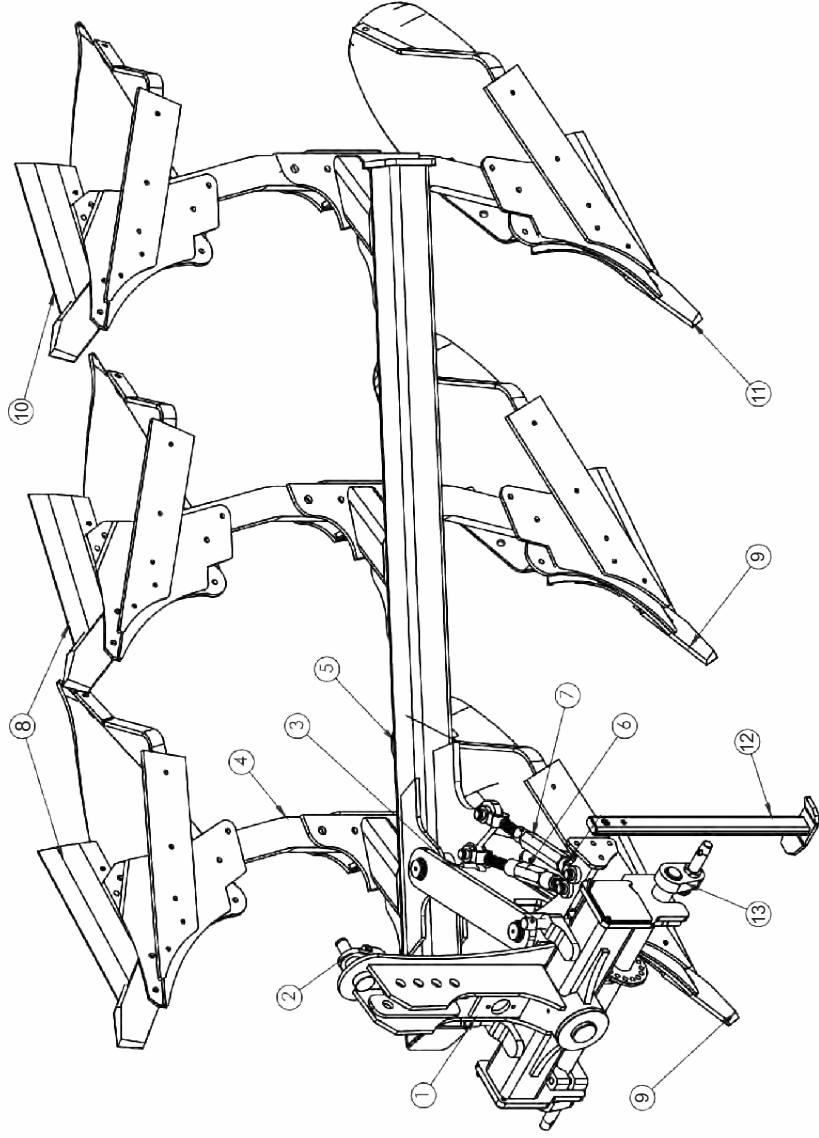

FLIP PLOW

SR.NO.	ASSEMBLY NAME	3 BOTTOM		2 BOTTOM	
		ASSEMBLY CODE	QTY.	ASSEMBLY CODE	QTY.
1	HEADSTOCK-75	76330016	1	76330016	1
2	HYDRAULIC CYLINDER 1 TON CAPACITY	71200031	1	71200031	1
3	CONNECTOR LINK ASSEMBLY	76350013	1	76350013	1
4	FLIP PLOWTYNE-36mm	10330035	6	10330035	4
5	BOX FRAME ASSEMBLY-36mm	76340004	1	76340003	1
6	TURNBUCKLE SMALL L-200	71200036	1	71200036	1
7	TURNBUCKLE BIG L-250	71200037	1	71200037	1
8	FRONT FURROW ASSEMBLY-RHS	76360018	2	76360018	1
9	FRONT FURROW ASSEMBLY-LHS	76360019	2	76360019	1
10	REAR FURROW ASSEMBLY-RHS	76360022	1	76360022	1
11	REAR FURROW ASSEMBLY-LHS	76360023	1	76360023	1
12	STAND ASSEMBLY	76330033	1	76330033	1
13	DRAWBAR ASSEMBLY	76330031	1	76330031	1

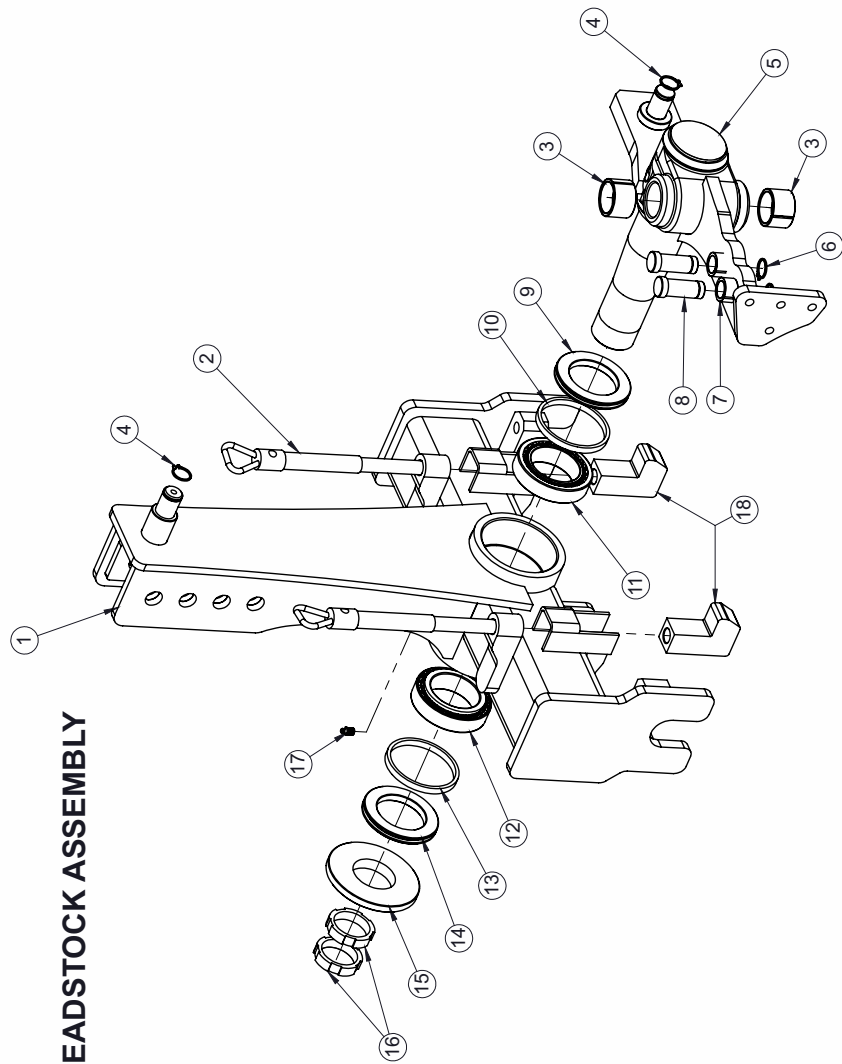

HEADSTOCK ASSEMBLY

HEAD STOCK ASSEMBLY			
SR. NO.	PART NAME	PART CODE	QTY
1	HEADSTOCK-75	76330016	1
2	HEADSTOCK STOPPER ROD WITH HANDLE	76330017	2
3	CONNECTOR HUB BUSH 55X45X35	76350005	2
4	EXTERNAL CIRCLIP A30 LIGHT	10390023	2
5	HEADSTOCK HUB AXLE ASSEMBLY-75	76330022	1
6	EXTERNAL CIRCLIP A25 LIGHT	10390024	2
7	CONNECTOR BUSH 35X25X20	76350003	2
8	TURNBUCKLE PIN Ø25X70	76330003	2
9	REAR SEAL WASHER	76330001	1
10	FELT RING 116x102x6	10040079	1
11	BEARING 33015	10050114	1
12	BEARING 32213	10050012	1
13	FELT RING 120x107x6	10040078	1
14	FRONT SEAL WASHER	76330004	1
15	FRONT PIPE COVER	76330021	1
16	RING NUT M65X2P	10280089	2
17	GREASE NIPPLE	10300005	1
18	HEADSTOCK STOPPER	76330020	2

CONNECTOR LINK ASSEMBLY

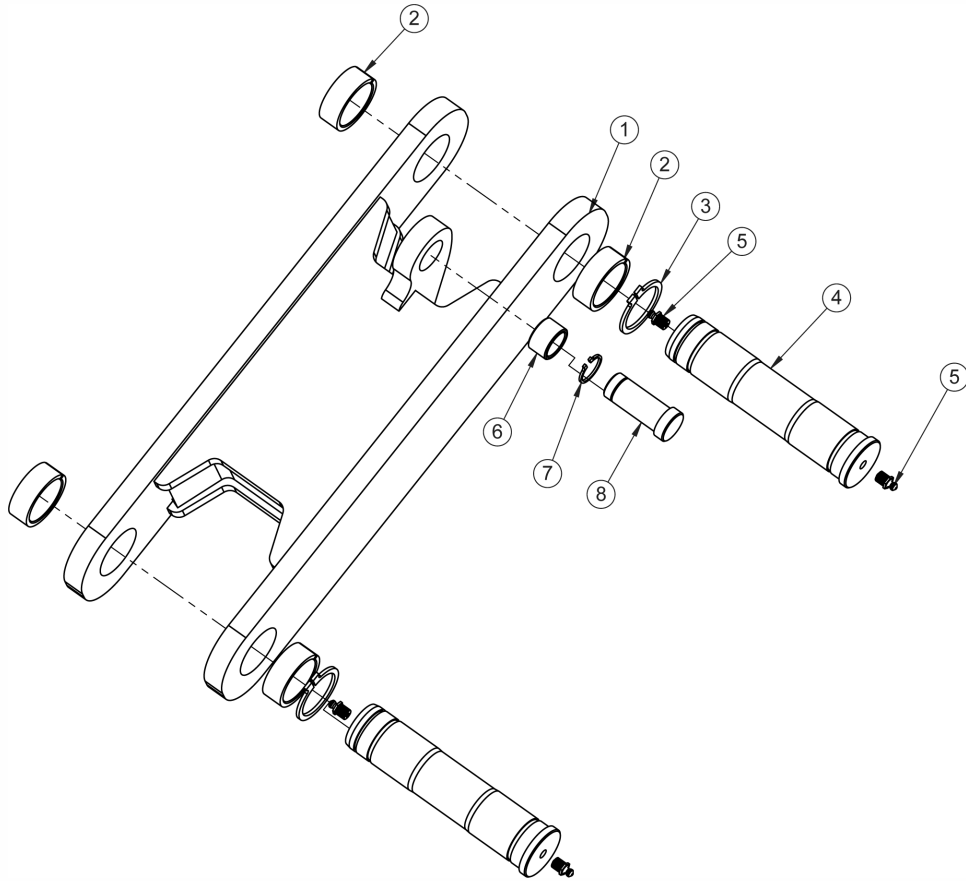

CONNECTOR LINK ASSEMBLY			
SR. NO.	PART NAME	PART CODE	QTY
1	CONNECTOR LINK ASSEMBLY	76350013	1
2	CONNECTOR BUSH 55X45X20	76350004	4
3	EXTERNAL CIRCLIP 45MM	10390020	2
4	CONNECTOR LINKAGE PIN Ø50X208	76350001	2
5	GREASE NIPPLE	10300005	4
6	CONNECTOR BUSH 35X25X20	76350003	1
7	EXTERNAL CIRCLIP 25MM	10390024	1
8	TURN BUCKLE PIN Ø25X70	76330003	1

BOX FRAME ASSEMBLY

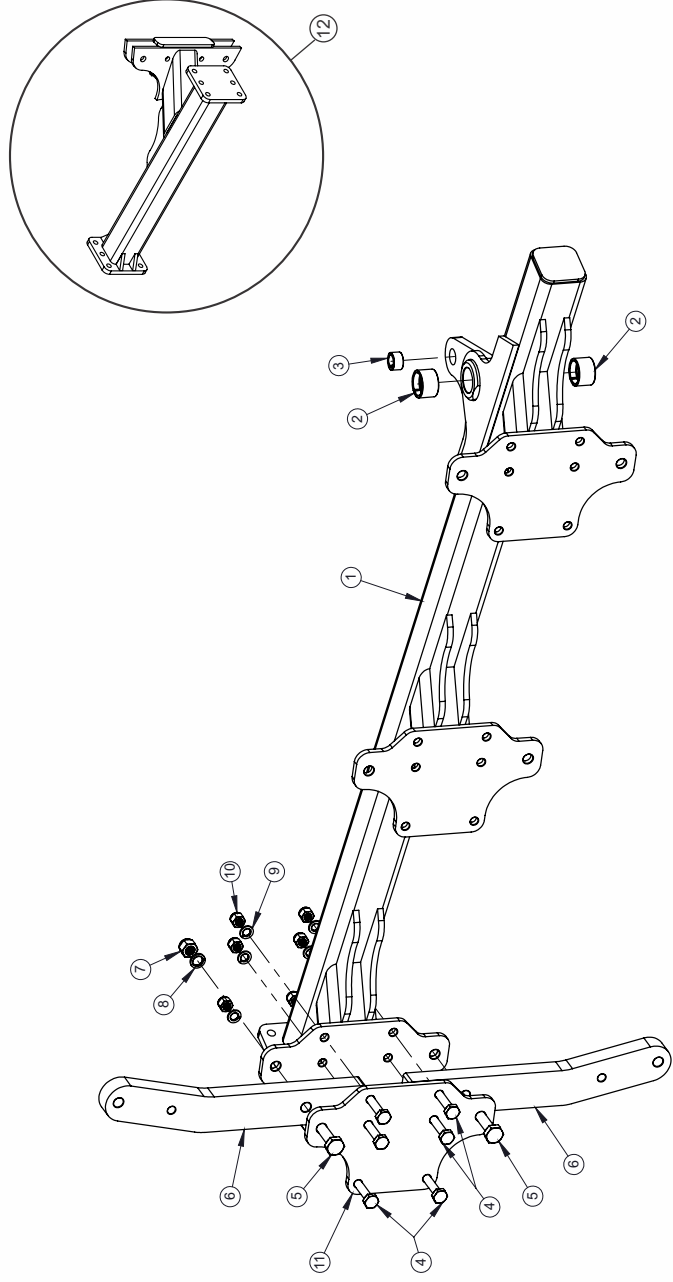

BOX FRAME ASSEMBLY						
SR NO.	PART NAME	3 BOTTOM		2 BOTTOM		QTY
		PART CODE	QTY	ERP CODE	QTY	
1	BOX FRAME ASSEMBLY	76340004	1	76340003	1	1
2	CONNECTOR HUB BUSH 55X45X35	76350005	2	76350005	2	2
3	CONNECTOR BUSH 35X25X20	76350003	1	76350003	1	1
4	HEX HEAD BOLT M16X85X2P (36mm Tyne)	10260383	18	10260383	12	12
	HEX HEAD BOLT M16X75X2P (25mm Tyne)	10260370	18	10260370	12	12
5	HEX HEAD BOLT M20X90X2.5P (36mm Tyne)	10260432	6	10260432	4	4
	HEX HEAD BOLT M20X80X2.5P (25mm Tyne)	10260517	6	10260517	4	4
6	TYNE-36mm	10330035	3	10330035	2	2
	TYNE-25mm	10330039	3	10330039	2	2
7	SPRING WASHER 20MM	10270016	6	10270016	4	4
8	NYLOCK NUT M20X2.5P	10280021	6	10280021	4	4
9	SPRING WASHER 16MM	10270005	6	10270005	4	4
10	NYLOCK NUT M16X2P	10280005	6	10280005	4	4
11	TINE MOUNTING PLATE	71200091	3	71200091	2	2
12	ADDITIONAL 1 BOTTOM ASSEMBLY (FOR 2+1 BOTTOM ONLY)			76310018	1	1

FLIP LOW FURROW ASSEMBLY-RHS

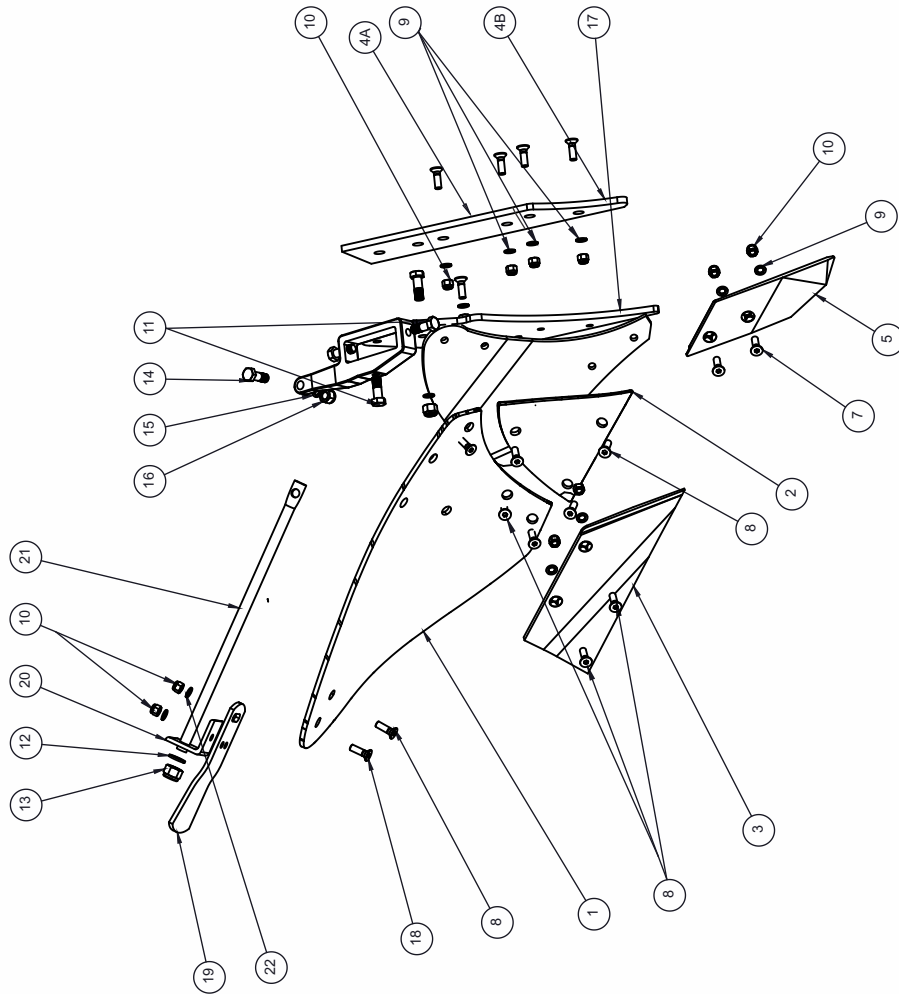

FURROW ASSEMBLY-RHS

SR.NO.	PART NAME	FRONT FURROW ASSEMBLY	REAR FURROW ASSEMBLY	QTY.
		ITEM CODE	ITEM CODE	
1	BIG MOULD BOARD-RHS	71200030	71200030	1
2	SMALL MOULD BOARD-LHS	71200027	71200027	1
3	PLOUGH SHARE-RHS	76360002	76360002	1
4 A	LANDSLIDE PLATE-RHS	76360008	76360008	1
4 B	LANDSLIDE WEDGE PLATE-RHS	76360037	76360037	1
5	PLOUGH POINT-RHS	76360001	76360001	1
6	MOULD BOARD SUPPORT STRIP-RHS	76360011	76360011	1
7	CSK BOLT M12X50X1.75P	10260050	10260050	2
8	CSK BOLT M12X40X1.75P	10260052	10260052	14
9	SPRING WASHER 12MM	10270003	10270003	17
10	PLAIN NUT M12X1.75P	10280028	10280028	18
11	HEX HEAD BOLT M16X50X2P	10260358	10260358	3
12	SPRING WASHER 20MM	10270016	10270016	1
13	NYLOCK NUT M20X2.5P	10270021	10270021	1
14	HEX HEAD BOLT M16X55X2P	10260454	10260454	1
15	SPRING WASHER 16MM	10270005	10270005	2
16	NYLOCK NUT M16X2P	10280005	10280005	2
17	FROG ASSEMBLY-RHS	76360020	76360020	1
18	HEX HEAD BOLT M12X50X1.75P	10260363	10260363	1
19	FURROW EXTENSION PLATE-RHS	76360025	76360025	1
20	FURROW SUPPORTING BRACKET	76360028	76360028	1
21	FURROW ADJUSTING ROD	76360027	76360027	1
22	PLAIN WASHER 12MM	10270010	10270010	1

FLIP PLOW FURROW ASSEMBLY-LHS

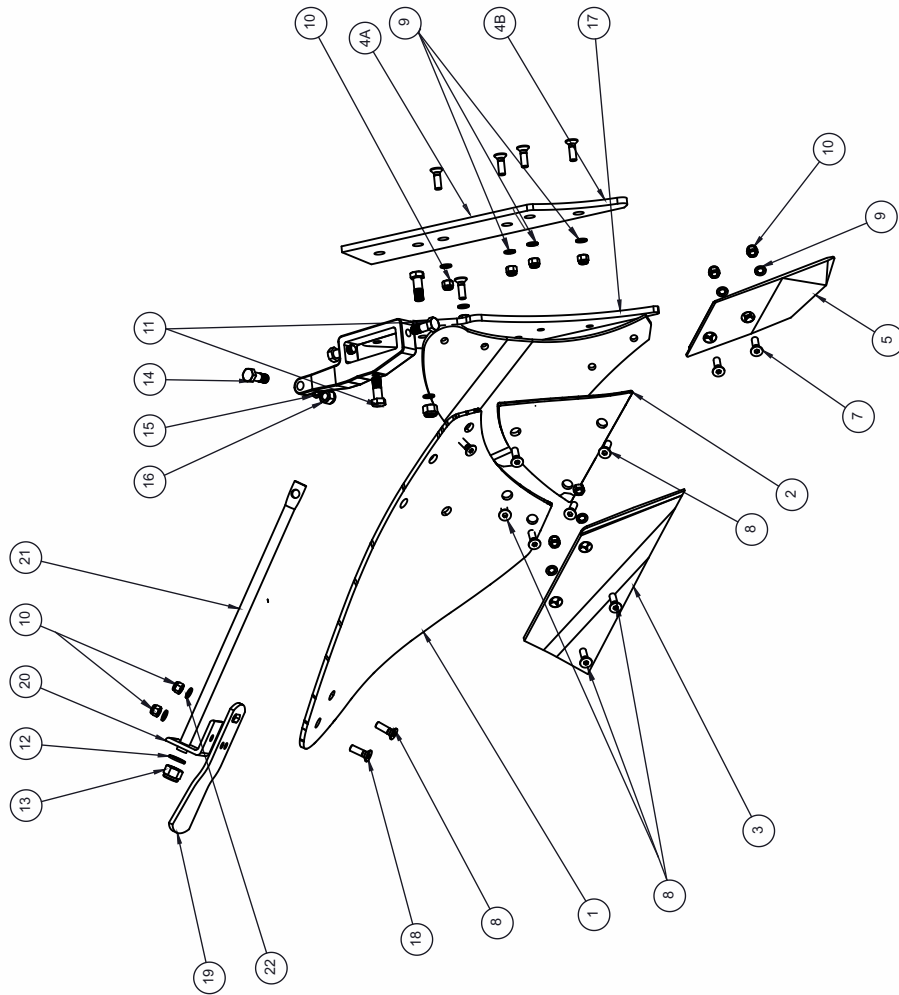

FLIP PLOW FURROW ASSEMBLY-LHS				
SR.NO.	PART NAME	FRONT FURROW ASSEMBLY	REAR FURROW ASSEMBLY	QTY.
		ITEM CODE	ITEM CODE	
1	BIG MOULD BOARD-LHS	71200029	71200029	1
2	SMALL MOULD BOARD-LHS	71200028	71200028	1
3	PLOUGH SHARE-LHS	76360003	76360003	1
4 A	LANDSLIDE PLATE-LHS	76360014	76360014	1
4 B	LANDSLIDE WEDGE PLATE-LHS	76360036	76360036	1
5	PLOUGH POINT-LHS	76360004	76360004	1
6	MOULD BOARD SUPPORT STRIP-LHS	76360017	76360017	1
7	CSK BOLT M12X50X1.75P	10260050	10260050	2
8	CSK BOLT M12X40X1.75P	10260052	10260052	14
9	SPRING WASHER 12MM	10270003	10270003	17
10	PLAIN NUT M12X1.75P	10280028	10280028	18
11	HEX HEAD BOLT M16X50X2P	10260358	10260358	3
12	SPRING WASHER 20MM	10270016	10270016	1
13	NYLOCK NUT M20X2.5P	10270021	10270021	1
14	HEX HEAD BOLT M16X55X2P	10260454	10260454	1
15	SPRING WASHER 16MM	10270005	10270005	2
16	NYLOCK NUT M16X2P	10280005	10280005	2
17	FROG ASSEMBLY-LHS	76360020	76360020	1
18	HEX HEAD BOLT M12X50X1.75P	10260363	10260363	1
19	FURROW EXTENSION PLATE-LHS	76360024	76360024	1
20	FURROW SUPPORTING BRACKET	76360028	76360028	1
21	FURROW ADJUSTING ROD	76360027	76360027	1
22	PLAIN WASHER 12MM	10270010	10270010	1

STAND MOUNTING ASSEMBLY

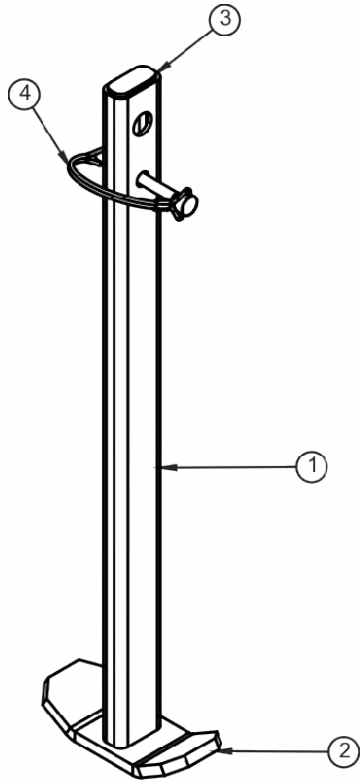

Sl. No.	Part Name	Part Code No.	Dimensions (mm)	Qty. (Nos.)
1	STAND ASSEMBLY	76330033		1
2	STAND PIPE	76330027	25x50x4Tx950L	1
3	STAND BASE	76330029	250x65x10	1
4	STAND PIPE TOP COVER	76330028	40x18x3	1
5	WIRE LOCK PIN	10020114	12X75	1

TYRE SET ASSEMBLY

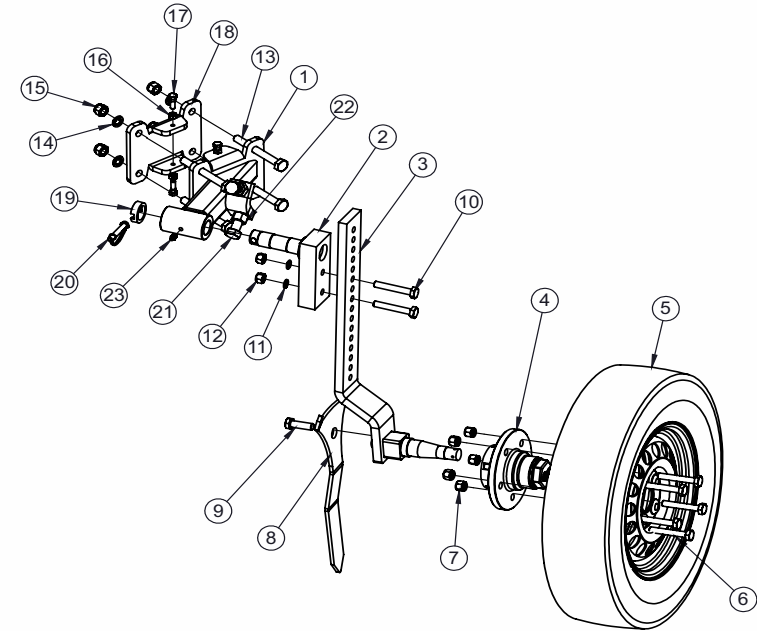

TYRE SET ASSEMBLY (76340052)			
SR. NO.	PART NAME	PART NO.	QTY.
1	TYRE SET FRAME ATTACHMENT ASSY	76340053	1
2	TYRE SET SPINDLE ASSEMBLY	76340054	1
3	TYRE SET AXLE ASSY	76340055	1
4	HUB ASSEMBLY	76340056	1
5	TYRE ASSEMBLY	77000001	1
6	HUB BOLT	10260227	5
7	HUB NUT	10280061	5
8	TYRE SET SCRAPER FLAT	76340066	1
9	HEX HEAD BOLT M16X2X50	10260358	1
10	HEX HEAD BOLT M14X2X90	10260508	2
11	SPRING WASHER 14 MM	10270004	2
12	NYLOCK NUT M14X2	10280090	2
13	HEX HEAD BOLT M16X2X150	10260405	4
14	SPRING WASHER 16 MM	10270005	4
15	NYLOCK NUT M16X2	10280025	4
16	PLAIN NUT M10X1.5	10280036	4
17	HEX HEAD BOLT M10X1.5X30	10260396	4
18	TYRE SET MOUNTING PLATE	76340059	1
19	TYRE SET SPINDLE LOCKING BUSH	76340065	1
20	WIRE LOCK PIN 12X75 (L)	10020114	1
21	HEX HEAD BOLT M20X2.5X65	10260316	2
22	PLAIN NUT M20X2.5	10280043	2
23	GREASE NIPPLE M10X1.5	10300089	1

HUB ASSEMBLY

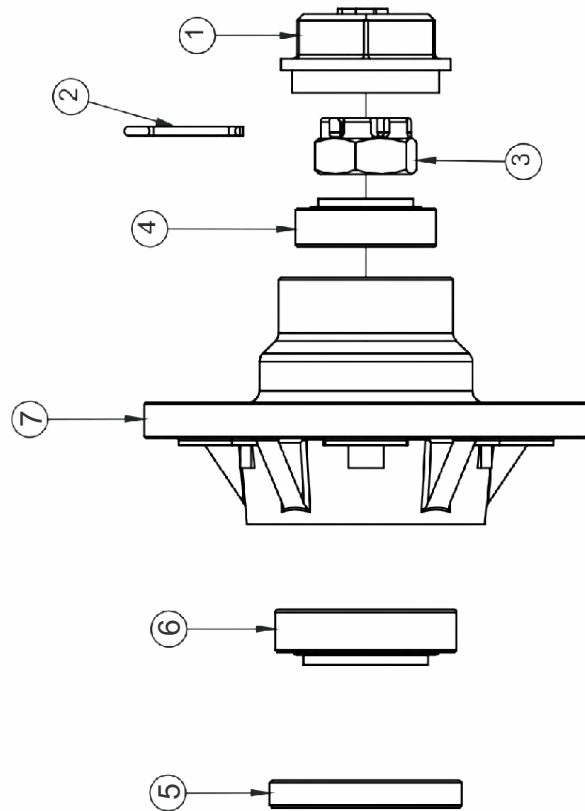

SL. NO.	PART NAME	PART NO.	QTY.
1	TYRE HUB COVER	10180008	1
2	SPLIT PIN 4X65M	10020055	1
3	CASTEL NUT ϕ 28X12G-20MM (T)	10280015	1
4	BEARING 32206	10050017	1
5	OIL SEAL45-85-12	10010038	1
6	BEARING 32208	10050021	1
7	HUB	77000006	1

DRAWBAR ASSEMBLY

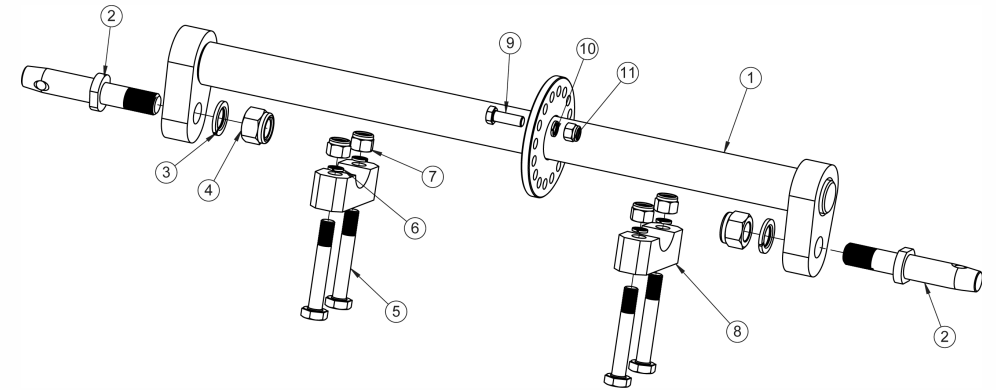

DRAWBAR ASSEMBLY			
SR.NO.	PART NAME	CODE NO.	QTY.
1	DRAW BAR ASSEMBLY-REVERSIBLE PLOUGH	76330031	1
2	HITCH PIN 32 MM	10020023	2
3	SPRING WASHER 25 MM	10270007	2
4	NYLOCK NUT M25	10280008	2
5	HEX HEAD BOLT M16X110X2P	10260022	4
6	SPRING WASHER 16 MM	10270005	4
7	NYLOCK NUT M16X2P	10280005	4
8	DRAWBAR CLAMP	76330014	2
9	HEX HEAD BOLT M12X40	10260273	1
10	SPRING WASHER 12MM	10270003	1
11	NYLOCK NUT M12	10280025	1

FAST MOVING SPARES		
SR. NO.	PART NAME	PART CODE
1	PLOUGH SHARE- LHS	76360003
2	PLOUGH SHARE- RHS	76360002
3	CONNECTOR HUB BUSH 55x45x35	76350005
4	CONNECTOR BUSH 32x25x20	76350003
5	SHARE POINT RHS	76360001
6	SHARE POINT LHS	76360004
7	HEX HEAD BOLT M16X85	10260309
8	HEAD STOCK STOPPER ASSEMBLY	76330017
9	PLAIN NUT M14X2P	10280092
10	EXTERNAL CIRCLIP A 25 LIGHT	10390024
11	EXTERNAL CIRCLIP A45X1.75 T	10390020
12	EXTERNAL CIRCLIP A30 LIGHT	10390023
13	LOWER HITCH PIN 32 MM	10020023
14	BEARING 33015	10050114
15	BEARING 32213	10050012
16	FRONT LANDSIDE SMALL PLATE-LHS 560X125X12	76360014
17	FRONT LANDSIDE SMALL PLATE-RHS 560X125X12	76360008
18	REAR BIG LANDSIDE PLATE - RHS 620X125X12	76360009
19	REAR BIG LANDSIDE PLATE - LHS 620X125X12	76360015

DELIVERY CHECKLIST

Dealer Pre-Delivery (Please Tick)	Please Complete all Dealer information Below
<p>1. Dealer Pre-Delivery Checklist</p> <ol style="list-style-type: none"> The customer or person responsible has been given the operator's manual. The customer undertakes to read the complete operator's manual and understands all aspects of the manual before operation of the machine. All safety, operational and maintenance information have been explained and demonstrated. All greasing and oil points, stickers, guarding and ID plate have been identified and physically pointed out. The customer agrees that it is his responsibility to read and carry out the safety, maintenance and operation as per this operator's manual. 	<p>Dealer Information</p> <p>Dealer's Name.....</p> <p>Address.....</p> <p>State..... Postcode.....</p> <p>Phone..... Fax.....</p> <p>Email.....</p> <p>Service Person.....</p> <p>I confirm that the pre-delivery service was performed on this machine.</p> <p>Signature.....</p> <p>Date.....</p> <p>Comments.....</p>
Customer Delivery (Please Tick)	Please Complete all Customer Information Below
<p>2. Customer Delivery Checklist</p> <ol style="list-style-type: none"> The customer or person responsible has been given the operator's manual. The customer undertakes to read the complete operator's manual and understands all aspects of the manual before operation of the machine. All safety, operational and maintenance information have been explained and demonstrated. All greasing and oil points, stickers, guarding and ID plate have been identified and physically pointed out. The customer agrees that it is his responsibility to read and carry out the safety, maintenance and operation as per this operator's manual. 	<p>Customer Information</p> <p>Customer's Name.....</p> <p>Address.....</p> <p>State..... Postcode.....</p> <p>Phone..... Fax.....</p> <p>Email.....</p> <p>Delivery Person.....</p> <p>I confirm that all of the delivery checks were explained and performed.</p> <p>Signature.....</p> <p>Delivery Date.....</p> <p>Comments.....</p>

FIELDKING

WARRANTY CARD Customer Copy

CUSTOMER NAME Mr./ Mrs :

ADDRESS :

MOBILE NO. :

Email :

NAME OF IMPLEMENT :

MODEL NO. :

YEAR OF Mfg. :

SERIAL NO. :

REGISTRATION NO. :

DATE OF PURCHASING :

NAME OF DEALER :

Customer's Signature

Dealer's Signature



Beri Udyog Pvt. Ltd.

Corporate Office : Plot No. 235-236 & 238-240, Sec-3, HSIIDC,
Karnal- 132001 (Haryana), India ☎ +91-184-2221571/ 72/ 73

✉ marketing@fieldking.com, exports@fieldking.com, 🌐 www.fieldking.com

FIELDKING

WARRANTY CARD Company Copy

CUSTOMER NAME Mr./ Mrs :

ADDRESS :

MOBILE NO. :

Email :

NAME OF IMPLEMENT :

MODEL NO. :

YEAR OF Mfg. :

SERIAL NO. :

REGISTRATION NO. :

DATE OF PURCHASING :

NAME OF DEALER :

Customer's Signature

Dealer's Signature



Beri Udyog Pvt. Ltd.

Corporate Office : Plot No. 235-236 & 238-240, Sec-3, HSIIDC,
Karnal- 132001 (Haryana), India ☎ +91-184-2221571/ 72/ 73

✉ marketing@fieldking.com, exports@fieldking.com, 🌐 www.fieldking.com

FIELDKING

WARRANTY CARD Dealer Copy

CUSTOMER NAME Mr./ Mrs :

ADDRESS :

MOBILE NO. :

Email :

NAME OF IMPLEMENT :

MODEL NO. :

YEAR OF Mfg. :

SERIAL NO. :

REGISTRATION NO. :

DATE OF PURCHASING :

NAME OF DEALER :

Customer's Signature

Dealer's Signature



Beri Udyog Pvt. Ltd.

Corporate Office : Plot No. 235-236 & 238-240, Sec-3, HSIIDC,
Karnal- 132001 (Haryana), India ☎ +91-184-2221571/ 72/ 73

✉ marketing@fieldking.com, exports@fieldking.com, 🌐 www.fieldking.com